

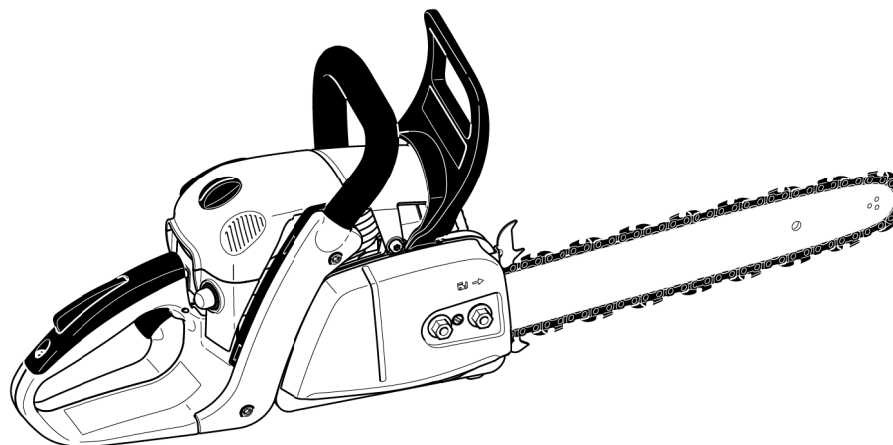

Spare Parts List
Ersatzteilliste
Liste de pièces détachées
Lista de piezas de repuesto

2013-02-18



DCS3500
DCS3501
DCS4300
DCS4300 (RUS)
DCS4301
MDE350
MDE354
MDE430
MDE435
MEA3500M
MEA3500MR
MEA3500L
MEA3500LR
MEA4300L
MEA4300LR
MEA4300G
MEA4300GR
EA3500F
EA3501F
EA4300F
EA4301F
CL350
CL430

995700540 (D, GB, F, E)

DCS3500, DCS3501, DCS4300, DCS4300 (RUS),
DCS4301, MDE350, MDE354, MDE430, MDE435,
MEA3500M, MEA3500MR, MEA3500L, MEA3500LR,
MEA4300L, MEA4300LR, MEA4300G, MEA4300GR,
EA3500F, EA3501F, EA4300F, EA4301F, CL350, CL430

1

Kraftstofftank, Bügelgriff
Fuel tank, tubular grip
Réserv. carburant, poignée tubulaire
Depósito de combustible, mango tubular

Makita[®]

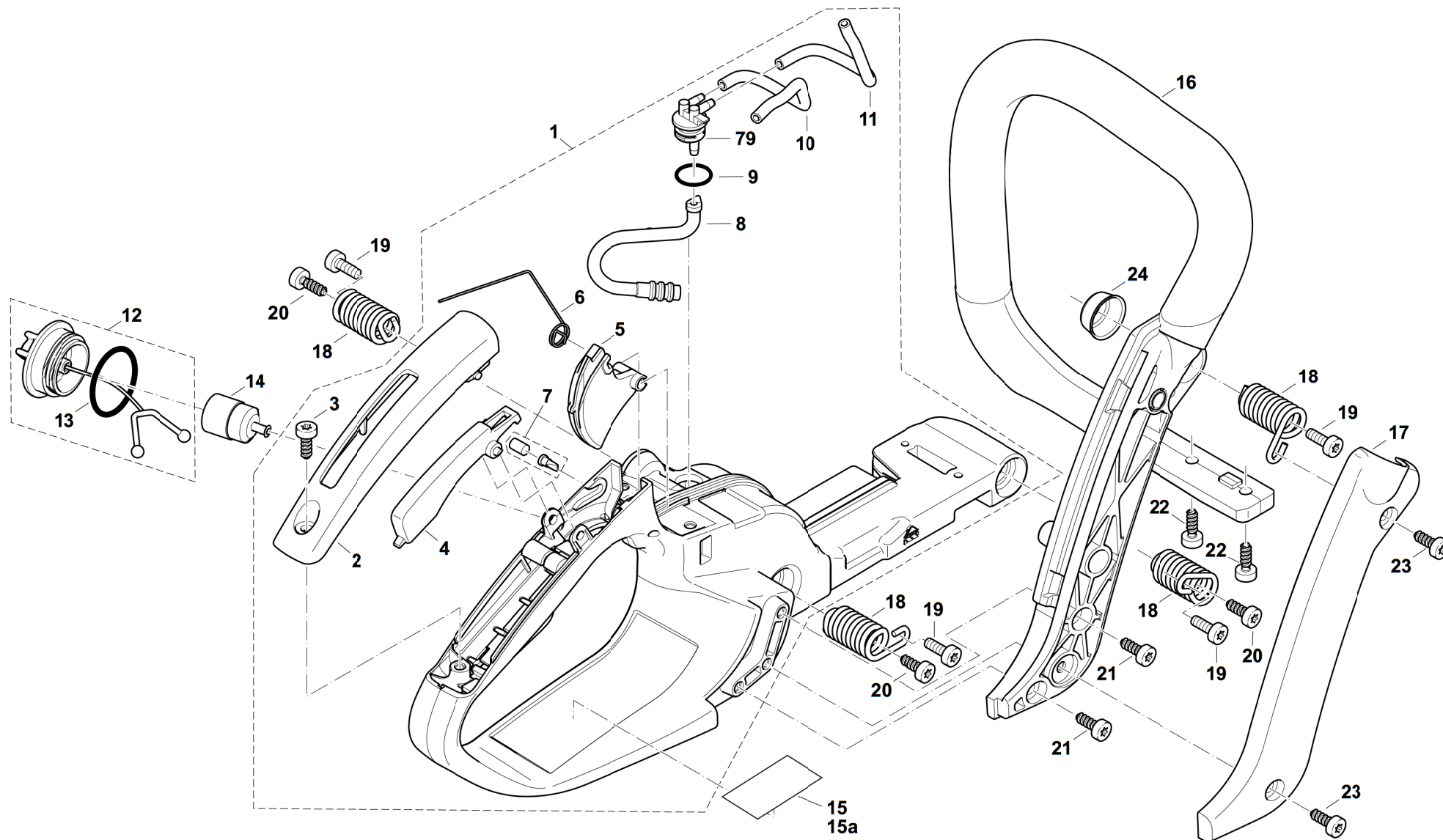

DCS3500, DCS3501, DCS4300, DCS4300 (RUS),
DCS4301, MDE350, MDE354, MDE430, MDE435,
MEA3500M, MEA3500MR, MEA3500L, MEA3500LR,
MEA4300L, MEA4300LR, MEA4300G, MEA4300GR,
EA3500F, EA3501F, EA4300F, EA4301F, CL350, CL430

1

Kraftstofftank, Bügelgriff
Fuel tank, tubular grip
Réserv. carburant, poignée tubulaire
Depósito de combustible, mango tubular



Seite / Page	Pos.	DCS3500	DCS3501	DCS4300	DCS4300 (RUS)	DCS4301	MDE350	MDE354	MDE430	MDE435	MEA3500M	MEA3500MR	MEA3500L	MEA3500LR	MEA4300L	MEA4300LR	MEA4300G	MEA4300GR	EA3500F	EA3501F	EA4300F	EA4301F	CL350	CL430	Teil-Nr. Part No. No. de pièce No. de pieza	Hinweise Notes Renseign. Nota	Bezeichnung	Spezifikation Specification	Description	Désignation	Denominación	
1	1											1		1				1						1	1	195 114 172		KRAFTSTOFFTANK KPL. ROT		FUEL TANK CPL. RED	RÉSERVOIR CPL. ROUGE	DEPÓSITO CPL. ROJO
1	1	1	1	1	1	1	1	1	1	1	1		1		1				1	1	1	1			195 114 672		KRAFTSTOFFTANK BLAU KPL.		FUEL TANK CPL. BLUE	RÉSERVOIR CPL. BLEU	DEPÓSITO CPL. AZUL	
1	1	1	1	1		1													1	1	1	1			195 114 650		KRAFTSTOFFTANK KPL. BLAU	USA (EPA), INCL.15a	TANK CPL. BLUE	RÉSERVOIR CPL. BLEU	DEPÓSITO CPL. AZUL	
1	2	1	1	1	1	1	1	1	1	1	1	1	1	1	1	1	1	1	1	1	1	1	1	1	1	195 117 050		GRIFFOBERSCHAL E		GRIP OUTER SHELL	COUILLE DE POIGNÉE SUPÉR.	CUBIERTA SUPER. EMPUÑADURA
1	3	1	1	1	1	1	1	1	1	1	1	1	1	1	1	1	1	1	1	1	1	1	1	1	1	913 455 164		INNENSTERN SCHRAUBE	5,5X16	SCREW	VIS	TORNILLO
1	4	1	1	1	1	1	1	1	1	1	1	1	1	1	1	1	1	1	1	1	1	1	1	1	1	195 117 030		GASHEBELSPERR E		CATCH LEVER	LEVIER DE VERROUILLAGE	PALANCA TRINCADA
1	5	1	1	1	1	1	1	1	1	1	1	1	1	1	1	1	1	1	1	1	1	1	1	1	1	195 117 020		GASHEBEL		THROTTLE LEVER	LEVIER D' ACCÉLÉRATIO N	ACELERADOR
1	6	1	1	1	1	1	1	1	1	1	1	1	1	1	1	1	1	1	1	1	1	1	1	1	1	195 117 010		GASHEBELFEDER		SPRING	RESSORT	MUELLE
1	7	1	1	1	1	1	1	1	1	1	1	1	1	1	1	1	1	1	1	1	1	1	1	1	1	170 175 010		SATZ BELÜFTUNGSVENT IL		AIR VALVE CPL.	SOUPAPE D'AERATION CPL.	VÁLVULA VENTILACION CPL.
1	8	1	1	1	1	1	1	1	1	1	1	1	1	1	1	1	1	1	1	1	1	1	1	1	1	195 114 050		KRAFTSTOFFLEITU NG		FUEL LINE	CONDUITE CARB.	TUBO COMB.
1	9	1	1	1	1	1	1	1	1	1	1	1	1	1	1	1	1	1	1	1	1	1	1	1	1	963 211 020		O-RING	11,5x2	O RING	ANNEAU TORIQUE	ANILLO OBTURADOR
1	10	1	1	1	1	1	1	1	1	1	1	1	1	1	1	1	1	1	1	1	1	1	1	1	1	965 452 090		VITONSCHLAUCH	2,5/5,5mm x1m L=118 mm	TUBE	GAINE	TUBO
1	11	1	1	1	1	1	1	1	1	1	1	1	1	1	1	1	1	1	1	1	1	1	1	1	1	965 452 660		VITONSCHLAUCH	5,6/3mmx1m EPA code, red L=93 mm	TUBE	GAINE	TUBO
1	12	1	1	1	1	1	1	1	1	1	1	1	1	1	1	1	1	1	1	1	1	1	1	1	1	181 114 202		TANKDECKEL KPL.		TANK CAP CPL.	BOUCHON RESERVOIR CPL.	TORNILLO DE CIERRE CPL.
1	13	2	2	2	2	2	2	2	2	2	2	2	2	2	2	2	2	2	2	2	2	2	2	2	2	963 229 036		O-RING	29,3X3,6	PACKING RING	BAGUE-JOINT	ANILLO DE GUARNICION
1	14	1	1	1	1	1	1	1	1	1	1	1	1	1	1	1	1	1	1	1	1	1	1	1	1	320 163 447		BENZINFILTER		FUEL FILTER	FILTRE D'ESSENCE	FILTRO DE GASOLINA
1	15						1	1	1	1	1	1	1	1	1	1	1	1						1	1	980 115 253		SICHERHEITSAUF KLEBER	J	CAUTION LABEL	PLAQUE	CALCOMANIA
1	15a	1	1	1		1													1	1	1	1						AUFKLEBER TANK	USA - EVAPORATION MAKITA	LABEL, TANK	PLAQUE, RÉSERVOIR	CALCOMANIA, DEPÓSITO
1	16	1	1	1	1	1	1	1	1	1	1	1	1	1	1	1	1	1	1	1	1	1	1	1	1	195 310 010		BÜGELGRIF KUNSTSTOFF		TUBULAR HANDLE	POIGNÉE TUBULAIRE	MANGO TUBULAR
1	17	1	1	1	1	1	1	1	1	1			1		1				1	1	1	1				195 310 651		ABDECKUNG SEITENSTREBE BLAU	MAKITA	COVER	COUVERCLE	CUBIERTA

DCS3500, DCS3501, DCS4300, DCS4300 (RUS),
DCS4301, MDE350, MDE354, MDE430, MDE435,
MEA3500M, MEA3500MR, MEA3500L, MEA3500LR,
MEA4300L, MEA4300LR, MEA4300G, MEA4300GR,
EA3500F, EA3501F, EA4300F, EA4301F, CL350, CL430

1

Kraftstofftank, Bügelgriff
Fuel tank, tubular grip
Réserv. carburant, poignée tubulaire
Depósito de combustible, mango tubular

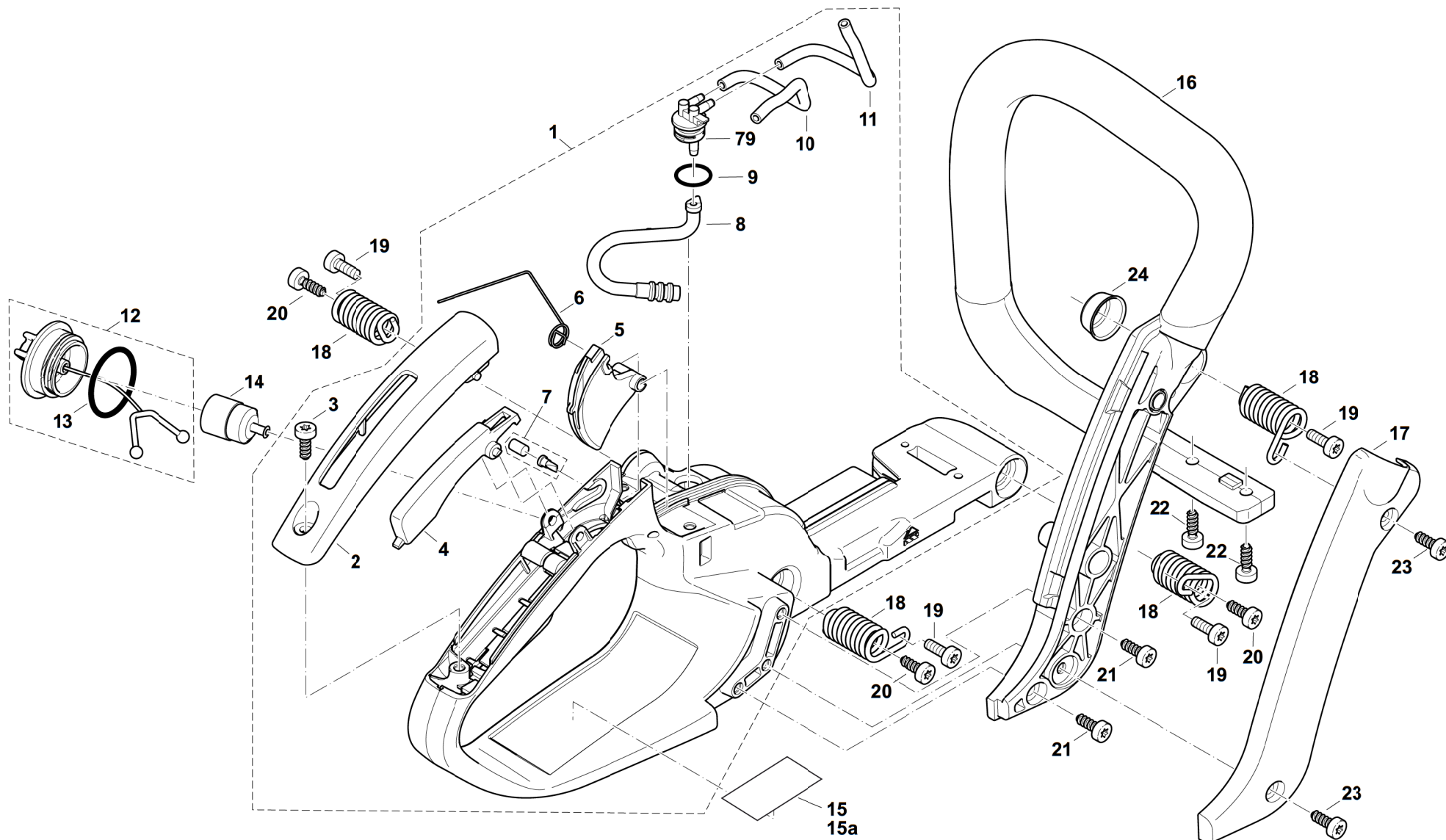

DCS3500, DCS3501, DCS4300, DCS4300 (RUS),
DCS4301, MDE350, MDE354, MDE430, MDE435,
MEA3500M, MEA3500MR, MEA3500L, MEA3500LR,
MEA4300L, MEA4300LR, MEA4300G, MEA4300GR,
EA3500F, EA3501F, EA4300F, EA4301F, CL350, CL430

1

Kraftstofftank, Bügelgriff
Fuel tank, tubular grip
Réserv. carburant, poignée tubulaire
Depósito de combustible, mango tubular



Seite / Page	Pos.	DCS3500	DCS3501	DCS4300	DCS4300 (RUS)	DCS4301	MDE350	MDE354	MDE430	MDE435	MEA3500M	MEA3500MR	MEA3500L	MEA3500LR	MEA4300L	MEA4300LR	MEA4300G	MEA4300GR	EA3500F	EA3501F	EA4300F	EA4301F	CL350	CL430	Teil-Nr. Part No. No. de pièce No. de pieza	Hinweise Notes Renseign. Nota	Bezeichnung	Spezifikation Specification	Description	Désignation	Denominación	
1	17												1	1	1			1								195 310 660		ABDECKUNG SEITENSTREBE SCHWARZ	MAKITA	COVER	COUVERCLE	CUBIERTA
1	17																						1	1	195 310 750		ABDECKUNG SEITENSTREBE ROT	RABBIT	COVER	COUVERCLE	CUBIERTA	
1	18	4	4	4	4	4	4	4	4	4	4	4	4	4	4	4	4	4	4	4	4	4	4	4	4	195 114 150		DÄMPFUNGSFEDE R	12	SPRING	RESSORT	RESORTE
1	19	4	4	4	4	4	4	4	4	4	4	4	4	4	4	4	4	4	4	4	4	4	4	4	4	908 005 165		SCHRAUBE INNEN6RD ZK	M5x16	H.L. SOCKET HEAD BOLT	VIS	TORNILLO
1	20	3	3	3	3	3	3	3	3	3	3	3	3	3	3	3	3	3	3	3	3	3	3	3	3	913 455 164		INNENSTERN SCHRAUBE	5,5X16	SCREW	VIS	TORNILLO
1	21	2	2	2	2	2	2	2	2	2	2	2	2	2	2	2	2	2	2	2	2	2	2	2	2	913 455 164		INNENSTERN SCHRAUBE	5,5X16	SCREW	VIS	TORNILLO
1	22	2	2	2	2	2	2	2	2	2	2	2	2	2	2	2	2	2	2	2	2	2	2	2	2	913 455 164		INNENSTERN SCHRAUBE	5,5X16	SCREW	VIS	TORNILLO
1	23	2	2	2	2	2	2	2	2	2	2	2	2	2	2	2	2	2	2	2	2	2	2	2	2	913 455 164		INNENSTERN SCHRAUBE	5,5X16	SCREW	VIS	TORNILLO
1	24	1	1	1	1	1	1	1	1	1	1	1	1	1	1	1	1	1	1	1	1	1	1	1	1	195 114 160		FEDERTOPF		SPRING GUIDING HEAD	TÊTE DE GUIDE DE RESSORT	COPA DE GUÍA DEL MUELLE
1	79	1	1	1	1	1	1	1	1	1	1	1	1	1	1	1	1	1	1	1	1	1	1	1	1	195 114 060		KRAFTSTOFFNIPP EL		FUEL NIPPLE	RACCORD FILETÉ	RACOR

DCS3500, DCS3501, DCS4300, DCS4300 (RUS),
DCS4301, MDE350, MDE354, MDE430, MDE435,
MEA3500M, MEA3500MR, MEA3500L, MEA3500LR,
MEA4300L, MEA4300LR, MEA4300G, MEA4300GR,
EA3500F, EA3501F, EA4300F, EA4301F, CL350, CL430

2

Abdeckhaube, Luftfilter
Hood, air filter
Capot protecteur, filtre à air
Cubierta protectora, filtro de aire

Makita[®]

Maschinen älterer Bauart
Previous models
Machines d'ancienne production
Máquinas de fabricación antigua

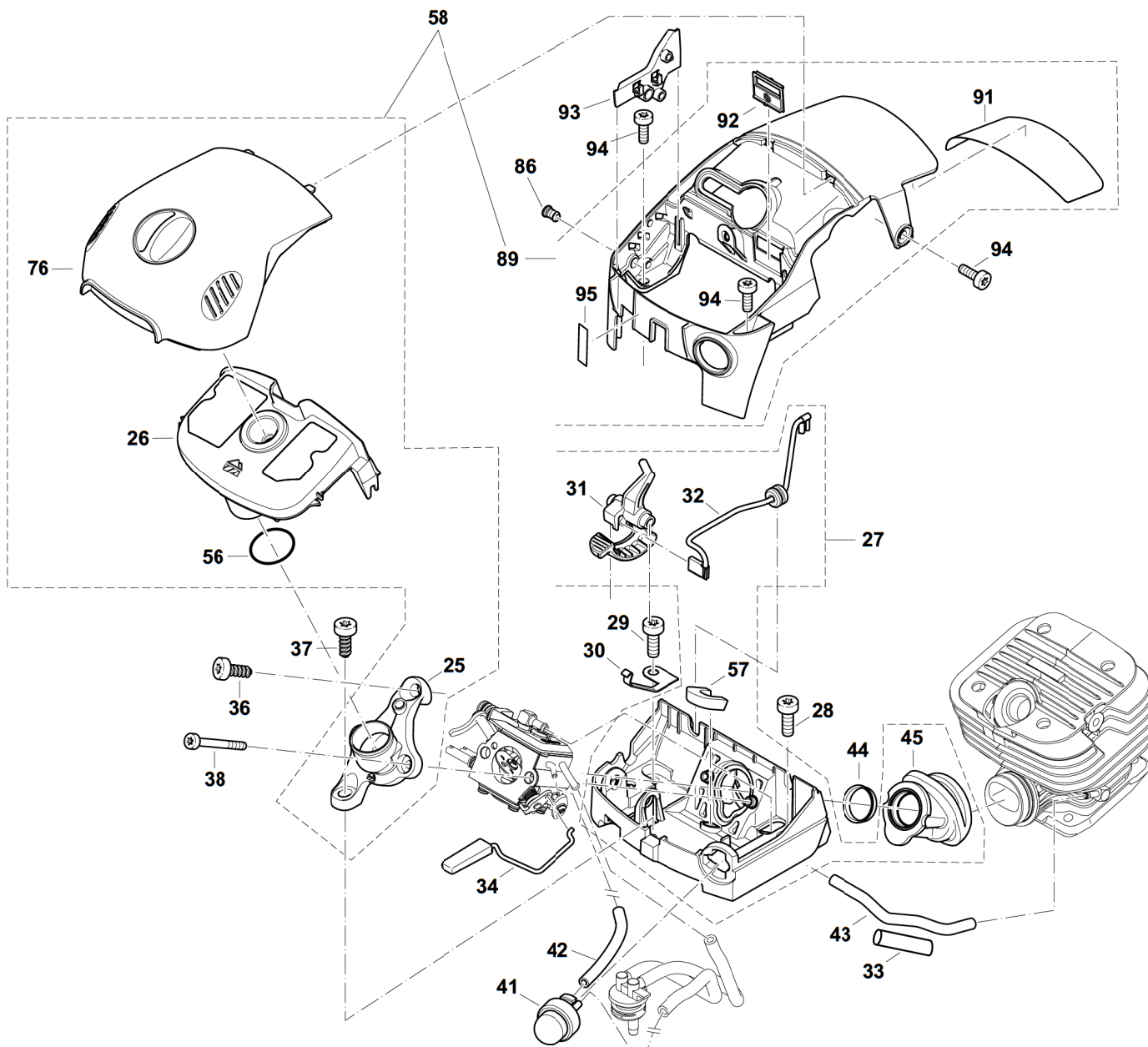
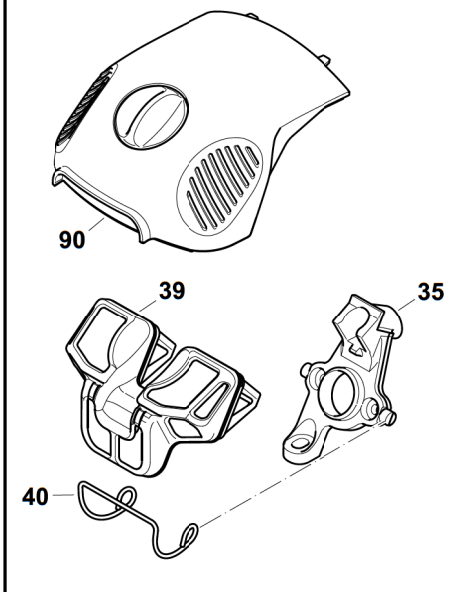

DCS3500, DCS3501, DCS4300, DCS4300 (RUS),
DCS4301, MDE350, MDE354, MDE430, MDE435,
MEA3500M, MEA3500MR, MEA3500L, MEA3500LR,
MEA4300L, MEA4300LR, MEA4300G, MEA4300GR,
EA3500F, EA3501F, EA4300F, EA4301F, CL350, CL430

2

Abdeckhaube, Luftfilter
Hood, air filter
Capot protecteur, filtre à air
Cubierta protectora, filtro de aire



Seite / Page	Pos.	DCS3500	DCS3501	DCS4300	DCS4300 (RUS)	DCS4301	MDE350	MDE354	MDE430	MDE435	MEA3500M	MEA3500MR	MEA3500L	MEA3500LR	MEA4300L	MEA4300LR	MEA4300G	MEA4300GR	EA3500F	EA3501F	EA4300F	EA4301F	CL350	CL430	Teil-Nr. Part No. No. de pièce No. de pieza	Hinweise Notes Renseign. Nota	Bezeichnung	Spezifikation Specification	Description	Désignation	Denominación	
2	25	1	1	1	1	1			1	1	1	1	1	1	1	1	1	1	1	1	1	1	1	1	1	195 171 020		ANSAUGKRÜMMER		CONNECTING MUFF	MANCHON DE JONCTION	MANGUITO DE CON.
2	26	1	1	1	1	1			1	1	1	1	1	1	1	1	1	1	1	1	1	1	1	1	195 173 150		LUFTFILTER KPL.	VLIES	AIR FILTER CPL.	FILTRE À AIR CPL.	FILTRO DE AIRE CPL.	
2	26	1	1	1	1	1			1	1	1	1	1	1	1	1	1	1	1	1	1	1	1	1	195 173 050		LUFTFILTER KPL.	NYLON	AIR FILTER CPL.	FILTRE À AIR CPL.	FILTRO DE AIRE CPL.	
2	27	1	1	1	1	1	1	1	1	1	1	1	1	1	1	1	1	1	1	1	1	1	1	1	195 131 301		VERGASERBODEN KPL.		BOTTOM CPL.	FOND CPL.	FONDO CPL.	
2	28	2	2	2	2	2	2	2	2	2	2	2	2	2	2	2	2	2	2	2	2	2	2	2	2	908 005 165		SCHRAUBE INNEN6RD ZK	M5x16	H.L. SOCKET HEAD BOLT	VIS	TORNILLO
2	29	2	2	2	2	2	2	2	2	2	2	2	2	2	2	2	2	2	2	2	2	2	2	2	2	908 005 165		SCHRAUBE INNEN6RD ZK	M5x16	H.L. SOCKET HEAD BOLT	VIS	TORNILLO
2	30	1	1	1	1	1	1	1	1	1	1	1	1	1	1	1	1	1	1	1	1	1	1	1	195 155 050		KONTAKTFEDER		CONTACT SPRING	RESSORT DE CONTACT	RESORTE DE CONTACTO	
2	31	1	1	1	1	1	1	1	1	1	1	1	1	1	1	1	1	1	1	1	1	1	1	1	195 155 021		CHOKEHEBEL		CHOKE LEVER	LEVIER DE STARTER	PALANCA ESTRANGULADOR DE AIRE	
2	32	1	1	1	1	1	1	1	1	1	1	1	1	1	1	1	1	1	1	1	1	1	1	1	195 147 010		KURZSCHLUSSKABEL		IGNITION CABLE	CÂBLE D' ALLUMAGE	CABLE CORTO-CIRC.	
2	33	m	m	m	m	m	m	m	m	m	m	m	m	m	m	m	m	m	m	m	m	m	m	m	m	970 502 110		ISOLIER SCHLAUCH	A6X0,5 L=30 mm	ISOLATING HOSE	TUYAU ISOLANT	MANGO AISLANTE
2	34	1	1	1	1	1	1	1	1	1	1	1	1	1	1	1	1	1	1	1	1	1	1	1	195 117 110		GASGESTÄNGE KPL.		THROTTLE LINKAGE CPL.	TRINGLE D' ACCÉLÉRATION CPL.	VARILLA ACELERADOR CPL.	
2	35	1	1	1	1	1	1	1	1	1	1	1	1	1	1	1	1	1	1	1	1	1	1	1	195 171 010		ANSAUGKRÜMMER		CONNECTING MUFF	MANCHON DE JONCTION	MANGUITO DE CON.	
2	36	1	1	1	1	1	1	1	1	1	1	1	1	1	1	1	1	1	1	1	1	1	1	1	913 455 164		INNENSTERN SCHRAUBE	5,5X16	SCREW	VIS	TORNILLO	
2	37	1	1	1	1	1	1	1	1	1	1	1	1	1	1	1	1	1	1	1	1	1	1	1	913 455 164		INNENSTERN SCHRAUBE	5,5X16	SCREW	VIS	TORNILLO	
2	38	2	2	2	2	2	2	2	2	2	2	2	2	2	2	2	2	2	2	2	2	2	2	2	2	908 004 405		ZYLINDERSCHRAUBE	4X40, 8.8	SCREW	VIS	TORNILLO
2	39	1	1	1	1	1	1	1	1	1	1	1	1	1	1	1	1	1	1	1	1	1	1	1	195 173 100		LUFTFILTER KPL.	NYLON	AIR FILTER CPL.	FILTRE À AIR CPL.	FILTRO DE AIRE CPL.	
2	40	1	1	1	1	1	1	1	1	1	1	1	1	1	1	1	1	1	1	1	1	1	1	1	181 171 050		KLAMMER FÜR LUFTFILTER		CLIP FOR AIR FILTER	BRIDE DE FIX. P. FILTRE À AIR	GRAPA PARA FILTRO DE AIRE	
2	41	1	1	1	1	1	1	1	1	1	1	1	1	1	1	1	1	1	1	1	1	1	1	1	010 155 010		KRAFTSTOFFPUMPE	PRIMER	PRIMER	POMPE À CARBURANT	BOMBA DE COMBUSTIBLE	
2	42	1	1	1	1	1	1	1	1	1	1	1	1	1	1	1	1	1	1	1	1	1	1	1	965 452 090		VITONSCHLAUCH	2,5/5,5mm x1m L=55 mm	TUBE	GAINE	TUBO	
2	43	1	1	1	1	1	1	1	1	1	1	1	1	1	1	1	1	1	1	1	1	1	1	1	965 452 090		VITONSCHLAUCH	2,5/5,5mm x1m L=93 mm	TUBE	GAINE	TUBO	

DCS3500, DCS3501, DCS4300, DCS4300 (RUS),
DCS4301, MDE350, MDE354, MDE430, MDE435,
MEA3500M, MEA3500MR, MEA3500L, MEA3500LR,
MEA4300L, MEA4300LR, MEA4300G, MEA4300GR,
EA3500F, EA3501F, EA4300F, EA4301F, CL350, CL430

2

Abdeckhaube, Luftfilter
Hood, air filter
Capot protecteur, filtre à air
Cubierta protectora, filtro de aire

Makita[®]

Maschinen älterer Bauart
Previous models
Machines d'ancienne production
Máquinas de fabricación antigua

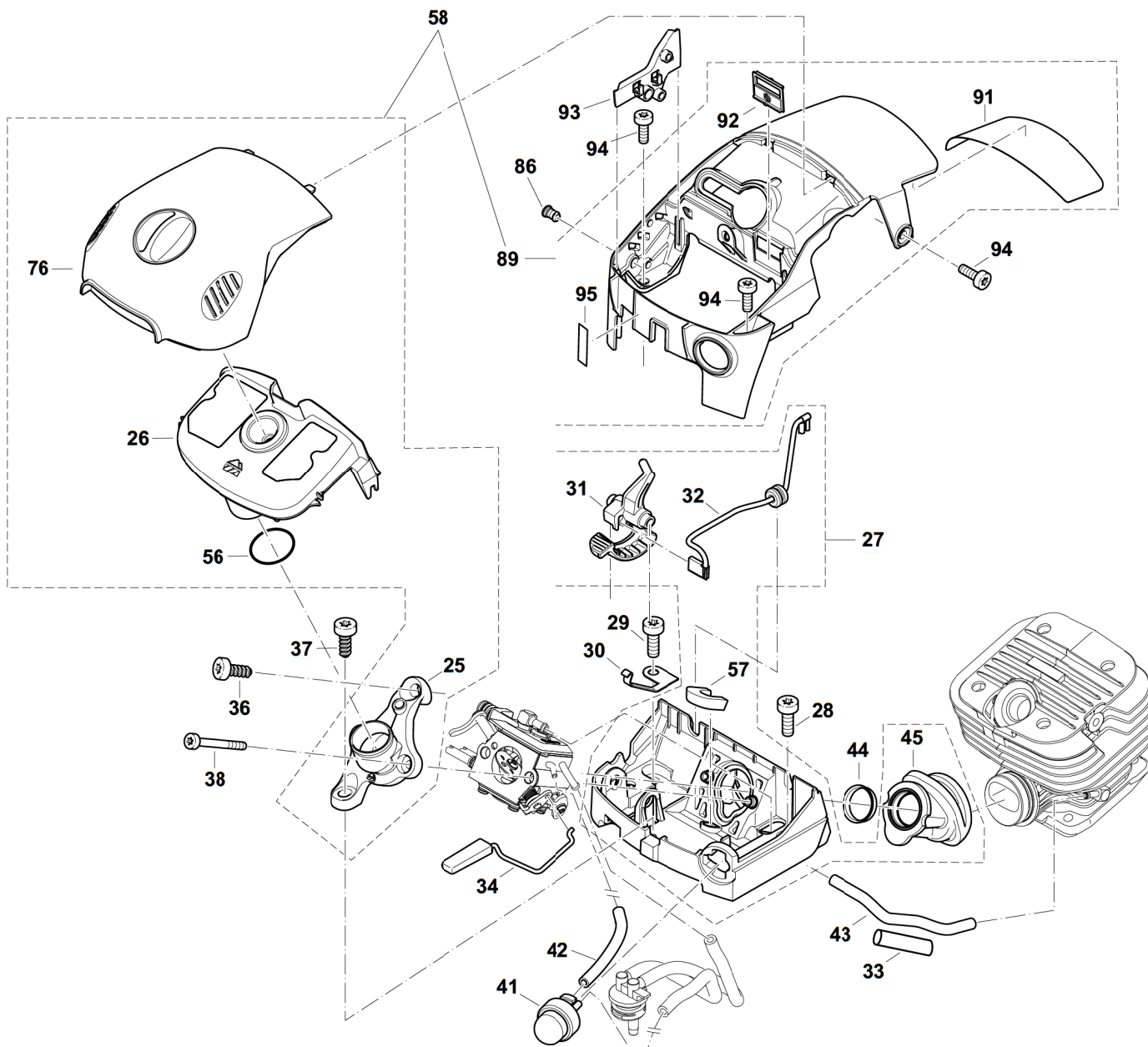
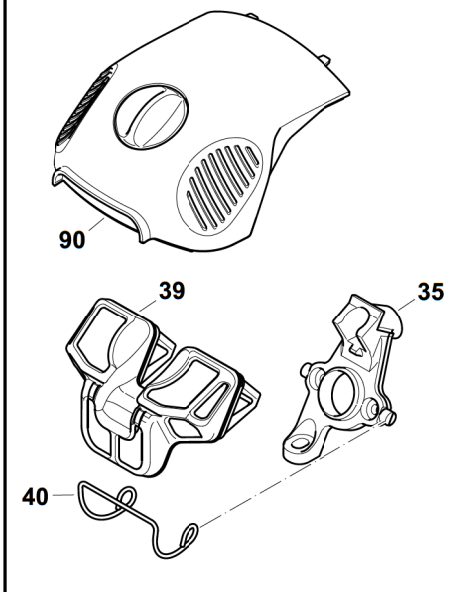

DCS3500, DCS3501, DCS4300, DCS4300 (RUS),
DCS4301, MDE350, MDE354, MDE430, MDE435,
MEA3500M, MEA3500MR, MEA3500L, MEA3500LR,
MEA4300L, MEA4300LR, MEA4300G, MEA4300GR,
EA3500F, EA3501F, EA4300F, EA4301F, CL350, CL430

2

Abdeckhaube, Luftfilter
Hood, air filter
Capot protecteur, filtre à air
Cubierta protectora, filtro de aire



Seite / Page	Pos.	DCS3500	DCS3501	DCS4300	DCS4300 (RUS)	DCS4301	MDE350	MDE354	MDE430	MDE435	MEA3500M	MEA3500MR	MEA3500L	MEA3500LR	MEA4300L	MEA4300LR	MEA4300G	MEA4300GR	EA3500F	EA3501F	EA4300F	EA4301F	CL350	CL430	Teil-Nr. Part No. No. de pièce No. de pieza	Hinweise Notes Renseign. Nota	Bezeichnung	Spezifikation Specification	Description	Désignation	Denominación	
2	44	1	1	1	1	1	1	1	1	1	1	1	1	1	1	1	1	1	1	1	1	1	1	1	1	181 131 021		EINSATZ FÜR ANSAUGSCHLAUCH		INSERT	PIÈCE D'INSERTION	PIEZA DE CIERRE
2	45	1	1	1	1	1	1	1	1	1	1	1	1	1	1	1	1	1	1	1	1	1	1	1	1	195 131 040		ANSAUGSCHLAUCH		SUCTION HOSE	TUYAU D'ASPIRATION	TUBO DE ASPIRACIÓN
2	56	1	1	1	1	1			1	1	1	1	1	1	1	1	1	1	1	1	1	1	1	1	1	963 220 013		O-RING	20x1,3	O RING	ANNEAU TORIQUE	ANILLO OBTURADOR
2	57	1	1	1	1	1	1	1	1	1	1	1	1	1	1	1	1	1	1	1	1	1	1	1	1	195 131 090		DICHTRING		PACKING RING	BAGUE-JOINT	ANILLO DE GUARNICIÓN
2	58	1	1	1	1	1			1	1	1		1		1				1	1	1	1	1	1	1	195 173 210	=> 2012-05	FILTERSET	NYLON	FILTER-SET	JEU DE POUR DECOUPEUSES	JUEGO DE FILTROS CORTADORAS
2	58	1	1	1	1	1			1	1	1		1		1				1	1	1	1	1	1	1	195 173 220	=> 2012-05	FILTERSET	VLIES	FILTER-SET	JEU DE POUR DECOUPEUSES	JUEGO DE FILTROS CORTADORAS
2	58	1	1	1	1	1			1	1	1		1		1				1	1	1	1	1	1	1	195 173 211	2012-06 =>	FILTERSET	NYLON	FILTER-SET	JEU DE POUR DECOUPEUSES	JUEGO DE FILTROS CORTADORAS
2	58	1	1	1	1	1			1	1	1		1		1				1	1	1	1	1	1	1	195 173 221	2012-06 =>	FILTERSET	VLIES	FILTER-SET	JEU DE POUR DECOUPEUSES	JUEGO DE FILTROS CORTADORAS
2	76	1	1	1	1	1			1	1	1		1		1				1	1	1	1	1	1	1	195 118 550		DECKEL KPL. SCHWARZ		COVER BLACK	CAPOT NOIR	CUBIERTA NEGRO
2	86	1	1	1	1	1	1	1	1	1									1	1	1	1				195 151 300	=> 2012-05	STOPFEN		PLUG	BOUCHON	TAPÓN
2	89	1	1	1	1	1			1	1	1		1		1				1	1	1	1	1	1	1	195 118 694		ABDECKHAUBE KPL. SCHWARZ		HOOD CPL. BLACK	CAPOT PROT. CPL. NOIR	TAPA PROT. CPL. NEGRO
2	89								1	1	1		1		1								1	1	1	195 118 171	=> 2009-11	ABDECKHAUBE KPL. ROT		HOOD CPL. RED	CAPOT PROT. CPL. ROUGE	TAPA PROT. CPL. ROJO
2	89	1	1	1		1	1	1	1	1																195 118 654	=> 2012-02	ABDECKHAUBE KPL. BLAU		HOOD CPL. BLUE	CAPOT PROT. CPL. BLEU	TAPA PROT. CPL. AZUL
2	90	1		1				1	1																	195 118 241	=> 2009-11	DECKEL KPL. ROT		COVER RED	CAPOT ROUGE	CUBIERTA ROJO
2	90	1	1	1		1	1	1	1	1																195 118 601	=> 2009-11	DECKEL KPL. GRAU		COVER GREY	CAPOT GRIS	CUBIERTA GRIS
2	91	1	1	1	1	1	1	1	1	1	1	1	1	1	1	1	1	1	1	1	1	1	1	1	1	195 118 080		SCHUTZFOLIE		PROTECTION FILM	FEUILLE PROTECTRICE	HOJA
2	92	1	1	1	1	1	1	1	1	1	1	1	1	1	1	1	1	1	1	1	1	1	1	1	1	195 118 140		EINSATZ	SO/WI	INSERT	PIÈCE D'INSERTION	PIEZA DE CIERRE
2	93	1	1	1	1	1	1	1	1	1	1	1	1	1	1	1	1	1	1	1	1	1	1	1	1	195 155 031	2011-11 =>	FÜHRUNG		GUIDE	GUIDAGE	GUÍA
2	94	3	3	3	3	3	3	3	3	3	3	3	3	3	3	3	3	3	3	3	3	3	3	3	3	908 005 165		SCHRAUBE INNEN6RD ZK	M5x16	H.L. SOCKET HEAD BOLT	VIS	TORNILLO
2	95	1	1	1	1	1	1	1	1	1	1	1	1	1	1	1	1	1	1	1	1	1	1	1	1	980 114 928		AUFKLEBER	CHOKE I-0	LABEL	PLAQUE	CALCOMANIA

DCS3500, DCS3501, DCS4300, DCS4300 (RUS),
 DCS4301, MDE350, MDE354, MDE430, MDE435,
 MEA3500M, MEA3500MR, MEA3500L, MEA3500LR,
 MEA4300L, MEA4300LR, MEA4300G, MEA4300GR,
 EA3500F, EA3501F, EA4300F, EA4301F, CL350, CL430

3

Kurbelgehäuse, Zylinder, Schalldämpfer
 Crankcase, cylinder, muffler
 Carter-vilebrequin, cylindre, pot d' échappement
 Carter cigüeñal, cilindro, silencioso



Maschinen älterer Bauart
 Previous models
 Machines d'ancienne production
 Máquinas de fabricación antigua

119

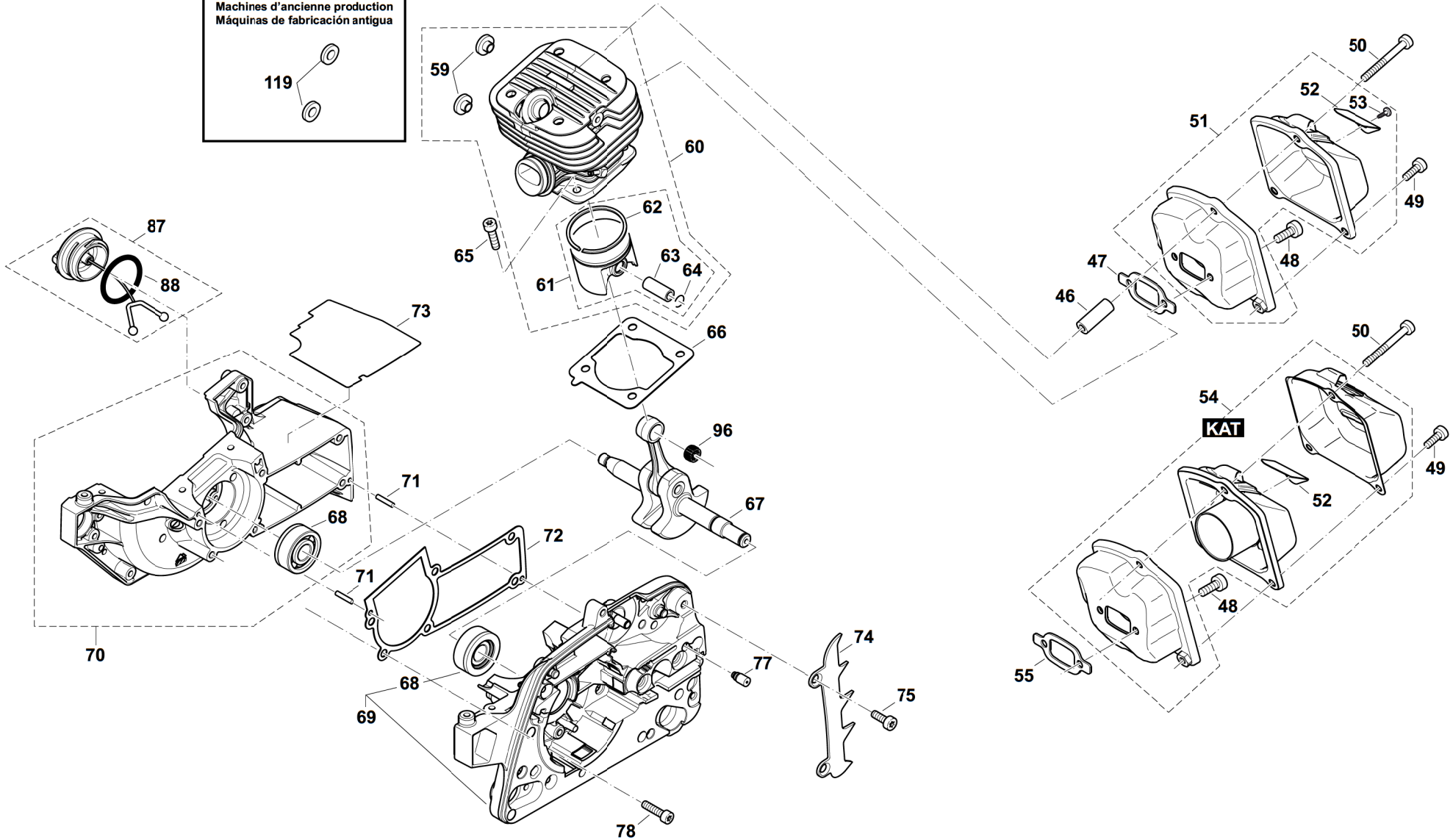

DCS3500, DCS3501, DCS4300, DCS4300 (RUS),
DCS4301, MDE350, MDE354, MDE430, MDE435,
MEA3500M, MEA3500MR, MEA3500L, MEA3500LR,
MEA4300L, MEA4300LR, MEA4300G, MEA4300GR,
EA3500F, EA3501F, EA4300F, EA4301F, CL350, CL430

3

Kurbelgehäuse, Zylinder, Schalldämpfer
Crankcase, cylinder, muffler
Carter-vilebrequin, cylindre, pot d' échappement
Carter cigüeñal, cilindro, silencioso



Seite / Page	Pos.	DCS3500	DCS3501	DCS4300	DCS4300 (RUS)	DCS4301	MDE350	MDE354	MDE430	MDE435	MEA3500M	MEA3500MR	MEA3500L	MEA3500LR	MEA4300L	MEA4300LR	MEA4300G	MEA4300GR	EA3500F	EA3501F	EA4300F	EA4301F	CL350	CL430	Teil-Nr. Part No. No. de pièce No. de pieza	Hinweise Notes Renseign. Nota	Bezeichnung	Spezifikation Specification	Description	Désignation	Denominación		
3	46	1	1	1	1	1	1	1	1	1	1	1	1	1	1	1	1	1	1	1	1	1	1	1	1	038 174 030		ZWISCHENSTÜCK	L=26,8mm	CONNECTING LINK	INTERMEDIARE	PIEZA INTERMEDIARIA	
3	47	1		1	1		1	1	1	1										1		1			965 522 033		DICHTUNG		GASKET	JOINT	JUNTA		
3	48	2	2	2	2	2	2	2	2	2	2	2	2	2	2	2	2	2	2	2	2	2	2	2	2	908 005 165		SCHRAUBE INNEN6RD ZK	M5x16	H.L. SOCKET HEAD BOLT	VIS	TORNILLO	
3	49	2	2	2	2	2	2	2	2	2	2	2	2	2	2	2	2	2	2	2	2	2	2	2	2	909 005 105		SCHRAUBE	M5x10	SCREW	VIS	TORNILLO	
3	50	1	1	1	1	1	1	1	1	1	1	1	1	1	1	1	1	1	1	1	1	1	1	1	1	908 305 405		SCHRAUBE INNEN6RD ZK	M5x40	H.L. SOCKET HEAD BOLT	VIS	TORNILLO	
3	51	1		1	1		1	1	1	1										1		1				195 174 500		SCHALLDÄMPFER KPL.		MUFFLER	POT D' ÉCHAPPEMENT	SILENCIADOR	
3	52	1	1	1	1	1	1	1	1	1	1	1	1	1	1	1	1	1	1	1	1	1	1	1	1	195 174 280		FUNKENSCHUTZSIEB		SPARK ARRESTER SCREEN	TAMIS	TAMIZ	
3	53	1		1	1		1	1	1	1										1		1				914 535 105		BLECHSCHRAUBE	3,5X9,5	SCREW	VIS	TORNILLO	
3	54		1			1					1	1	1	1	1	1	1	1	1				1	1	1	195 174 550		SCHALLDÄMPFER KPL.	KAT	MUFFLER	POT D' ÉCHAPPEMENT	SILENCIADOR	
3	55		1			1					1	1	1	1	1	1	1	1	1			1	1	1	1	195 174 060		DICHTUNG FÜR SCHALLDÄMPFER	KAT	GASKET	JOINT	JUNTA	
3	59	2	2	2	2	2	2	2	2	2	2	2	2	2	2	2	2	2	2	2	2	2	2	2	2	195 143 030	106000 =>	ISOLIERSCHEIBE	black	ISOLATING WASHER	RONDELLE	ARANDELA	
3	60	1	1				1	1																		194 131 201		ZYLINDER / KOLBEN KPL.	Ø 38	CYLINDER / PISTON CPL.	CYLINDRE ET PISTON CPL.	CILINDRO CON PISTÓN CPL.	
3	60										1	1	1	1					1	1				1		194 131 202		ZYLINDER / KOLBEN KPL.	Ø 38 (S)	CYLINDER / PISTON CPL.	CYLINDRE ET PISTON CPL.	CILINDRO CON PISTÓN CPL.	
3	60			1		1			1	1																195 131 201		ZYLINDER / KOLBEN KPL.	Ø 42	CYLINDER / PISTON CPL.	CYLINDRE ET PISTON CPL.	CILINDRO CON PISTÓN CPL.	
3	60				1								1	1	1	1	1	1				1	1	1	1	195 131 202		ZYLINDER / KOLBEN KPL.	Ø 42 (S)	CYLINDER / PISTON CPL.	CYLINDRE ET PISTON CPL.	CILINDRO CON PISTÓN CPL.	
3	61	1	1				1	1			1	1	1	1					1	1				1	1	194 132 100		KOLBEN KPL.	Ø 38	PISTON CPL.	PISTON CPL.	PISTÓN CPL.	
3	61			1	1	1			1	1				1	1	1	1	1						1	1	195 132 100		KOLBEN KPL.	Ø 42	PISTON CPL.	PISTON CPL.	PISTÓN CPL.	
3	62	1	1				1	1			1	1	1	1					1	1				1	1	194 132 020		KOLBENRING	Ø 38	PISTON RING	SEGMENT DE PISTON	SEGMENTO DE PISTÓN	
3	62			1	1	1			1	1				1	1	1	1	1				1	1	1	1	195 132 020		KOLBENRING	Ø 42	PISTON RING	SEGMENT DE PISTON	SEGMENTO DE PISTÓN	
3	63	1	1	1	1	1	1	1	1	1	1	1	1	1	1	1	1	1	1	1	1	1	1	1	1	195 132 030		KOLBENBOLZEN		PISTON PIN	AXE DE PISTON	PERNO DE PISTÓN	
3	64	2	2	2	2	2	2	2	2	2	2	2	2	2	2	2	2	2	2	2	2	2	2	2	2	2	195 132 050		SPRENGRING		SPRING RING	ANNEAU-RESSORT	ANILLO ELÁSTICO
3	65	4	4	4	4	4	4	4	4	4	4	4	4	4	4	4	4	4	4	4	4	4	4	4	4	4	908 405 205		SCHRAUBE INNEN6RD ZK	M5x20	H.L. SOCKET HEAD BOLT	VIS	TORNILLO
3	66	1	1	1	1	1	1	1	1	1	1	1	1	1	1	1	1	1	1	1	1	1	1	1	1	195 131 130		ZYLINDERFUßDICHTUNG		GASKET	JOINT	JUNTA	
3	67	1	1	1	1	1	1	1	1	1	1	1	1	1	1	1	1	1	1	1	1	1	1	1	1	195 120 300		KURBELWELLE KPL.		CRANKSHAFT CPL.	VILEBREQUIN CPL.	CIGÜEÑAL CPL.	
3	68	2	2	2	2	2	2	2	2	2	2	2	2	2	2	2	2	2	2	2	2	2	2	2	2	2	960 123 129		KOMBIKUGELLAGER		COMBINATION BALL BEARING	ROULEMENT À BILLES COMBINÉ	RODAMIENTO COMBI

DCS3500, DCS3501, DCS4300, DCS4300 (RUS),
 DCS4301, MDE350, MDE354, MDE430, MDE435,
 MEA3500M, MEA3500MR, MEA3500L, MEA3500LR,
 MEA4300L, MEA4300LR, MEA4300G, MEA4300GR,
 EA3500F, EA3501F, EA4300F, EA4301F, CL350, CL430

3

Kurbelgehäuse, Zylinder, Schalldämpfer
 Crankcase, cylinder, muffler
 Carter-vilebrequin, cylindre, pot d' échappement
 Carter cigüeñal, cilindro, silencioso



Maschinen älterer Bauart
 Previous models
 Machines d'ancienne production
 Máquinas de fabricación antigua

119

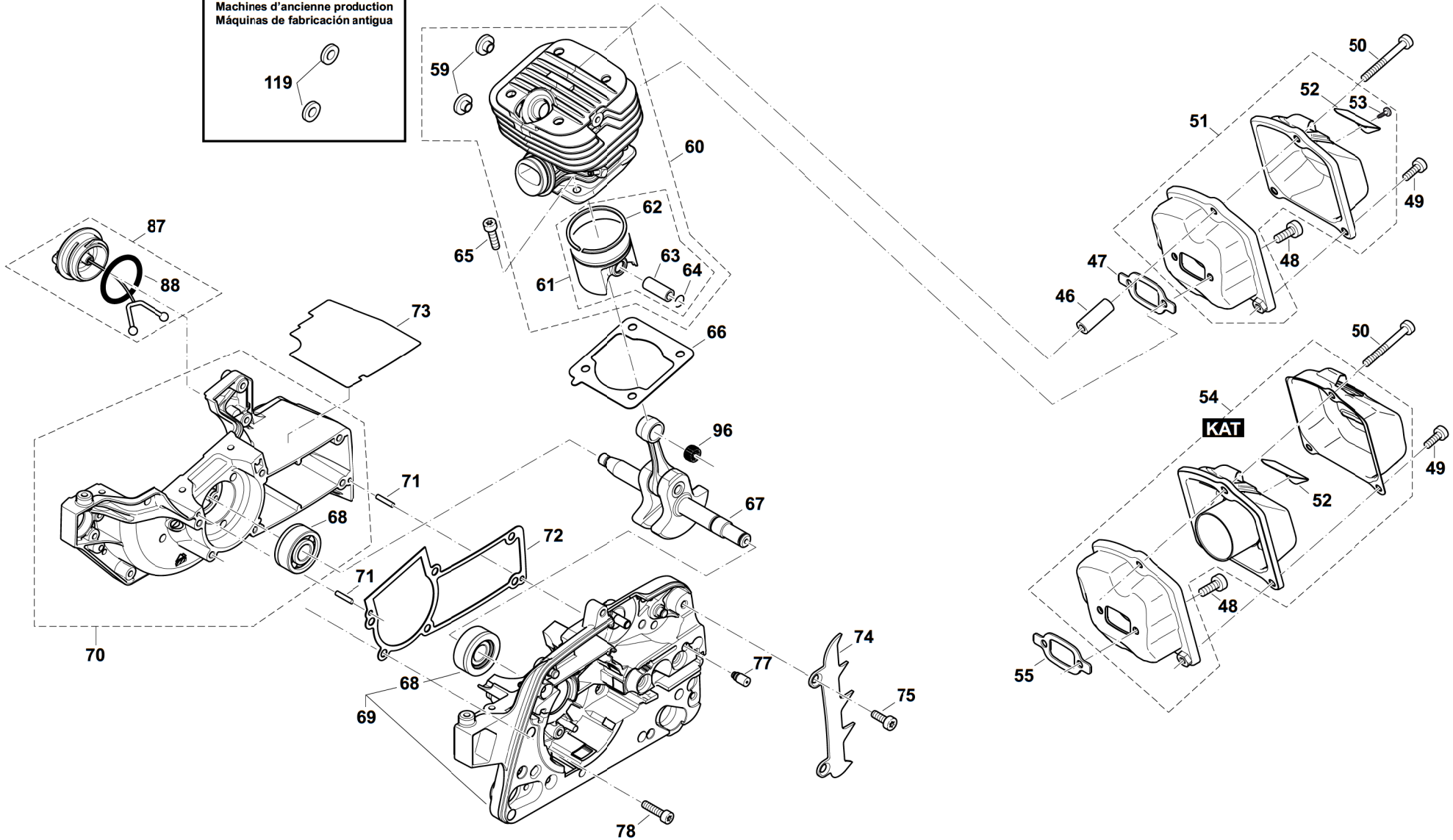

DCS3500, DCS3501, DCS4300, DCS4300 (RUS),
DCS4301, MDE350, MDE354, MDE430, MDE435,
MEA3500M, MEA3500MR, MEA3500L, MEA3500LR,
MEA4300L, MEA4300LR, MEA4300G, MEA4300GR,
EA3500F, EA3501F, EA4300F, EA4301F, CL350, CL430

3

Kurbelgehäuse, Zylinder, Schalldämpfer
Crankcase, cylinder, muffler
Carter-vilebrequin, cylindre, pot d' échappement
Carter cigüeñal, cilindro, silencioso



Seite / Page	Pos.	DCS3500	DCS3501	DCS4300	DCS4300 (RUS)	DCS4301	MDE350	MDE354	MDE430	MDE435	MEA3500M	MEA3500MR	MEA3500L	MEA3500LR	MEA4300L	MEA4300LR	MEA4300G	MEA4300GR	EA3500F	EA3501F	EA4300F	EA4301F	CL350	CL430	Teil-Nr. Part No. No. de pièce No. de pieza	Hinweise Notes Renseign. Nota	Bezeichnung	Spezifikation Specification	Description	Désignation	Denominación	
3	69										1		1		1		1							1	1	195 111 112		KURBELGEHÄUSE KS ROT		CRANKC. CL. SIDE RED	CARTER-COTÉ EM. ROUGE	CÁRTER CIG. LADO EM. ROJO
3	69	1	1	1	1	1	1	1	1	1		1		1		1			1	1	1	1			195 111 612		KURBELGEHÄUSE KS BLAU		CRANKC. CL. SIDE BLUE	CARTER-COTÉ EM. BLEU	CÁRTER CIG. LADO EM. AZUL	
3	70										1		1		1		1						1	1	195 111 122		KURBELGEHÄUSE MS ROT	INCL. 68	CRANKCASE MAGN. SIDE RED	CARTER-COTÉ MA. ROUGE	CÁRTER CIG. LADO MA. ROJO	
3	70	1	1	1	1	1	1	1	1	1		1		1		1			1	1	1	1			195 111 622		KURBELGEHÄUSE MS BLAU	INCL. 68	CRANKC. M. SIDE BLUE	CARTER-COTÉ MA. BLEU	CÁRTER CIG. LADO MA. AZUL	
3	71	2	2	2	2	2	2	2	2	2	2	2	2	2	2	2	2	2	2	2	2	2	2	2	2	936 430 160		SPIRALSPANNSTIFT	3X16	CLAMPING PIN	GOUPILLE	PASADOR
3	72	1	1	1	1	1	1	1	1	1	1	1	1	1	1	1	1	1	1	1	1	1	1	1	1	195 111 061		KURBELGEHÄUSEDIC HTUNG		GASKET	JOINT	JUNTA
3	73	1	1	1	1	1	1	1	1	1	1	1	1	1	1	1	1	1	1	1	1	1	1	1	1	195 111 080		SCHUTZFOLIE		PROTECTION FILM	FEUILLE PROTECTRICE	HOJA
3	74	1	1	1	1	1	1	1	1	1	1	1	1	1	1	1	1	1	1	1	1	1	1	1	1	195 250 010		ZACKENLEISTE		SPIKE BAR	BARRE DENTÉE	BARRA DENTADA
3	75	2	2	2	2	2	2	2	2	2	2	2	2	2	2	2	2	2	2	2	2	2	2	2	2	908 005 165		SCHRAUBE INNEN6RD ZK	M5x16	H.L. SOCKET HEAD BOLT	VIS	TORNILLO
3	77	1	1	1	1	1	1	1	1	1	1	1	1	1	1	1	1	1	1	1	1	1	1	1	1	010 245 030		BELÜFTUNGSVENTIL		VENT VALVE	SOUPAPE D AERATION	VALVULA VENTILACION
3	78	6	6	6	6	6	6	6	6	6	6	6	6	6	6	6	6	6	6	6	6	6	6	6	6	908 405 205		SCHRAUBE INNEN6RD ZK	M5x20	H.L. SOCKET HEAD BOLT	VIS	TORNILLO
3	87	1	1	1	1	1	1	1	1	1	1	1	1	1	1	1	1	1	1	1	1	1	1	1	1	181 114 202		TANKDECKEL KPL.		TANK CAP CPL.	BOUCHON RESERVOIR CPL.	TORNILLO DE CIERRE CPL.
3	88	2	2	2	2	2	2	2	2	2	2	2	2	2	2	2	2	2	2	2	2	2	2	2	2	963 229 036		O-RING	29,3X3,6	PACKING RING	BAGUE-JOINT	ANILLO DE GUARNICION
3	96	1	1	1	1	1	1	1	1	1	1	1	1	1	1	1	1	1	1	1	1	1	1	1	1	962 211 007		NADELKÄFIG	K9X12X11,5	NEEDLE CAGE	CAGE A AIGUILLES	JAULA DE AGUJAS
3	119	2	2	2		2	2	2	2	2																195 143 020 => 105999		ISO-SCHEIBE, BRAUN		WASHER, BROWN	RONDELLE, BRUN	ARANDELA, MARRÓN

DCS3500, DCS3501, DCS4300, DCS4300 (RUS),
DCS4301, MDE350, MDE354, MDE430, MDE435,
MEA3500M, MEA3500MR, MEA3500L, MEA3500LR,
MEA4300L, MEA4300LR, MEA4300G, MEA4300GR,
EA3500F, EA3501F, EA4300F, EA4301F, CL350, CL430

4

Zündelektronik, Anwerfvorrichtung
Ignition electronics, starter
Allumage électronique, dispositif de démarrage
Bobina encendido, dispositivo de arranque

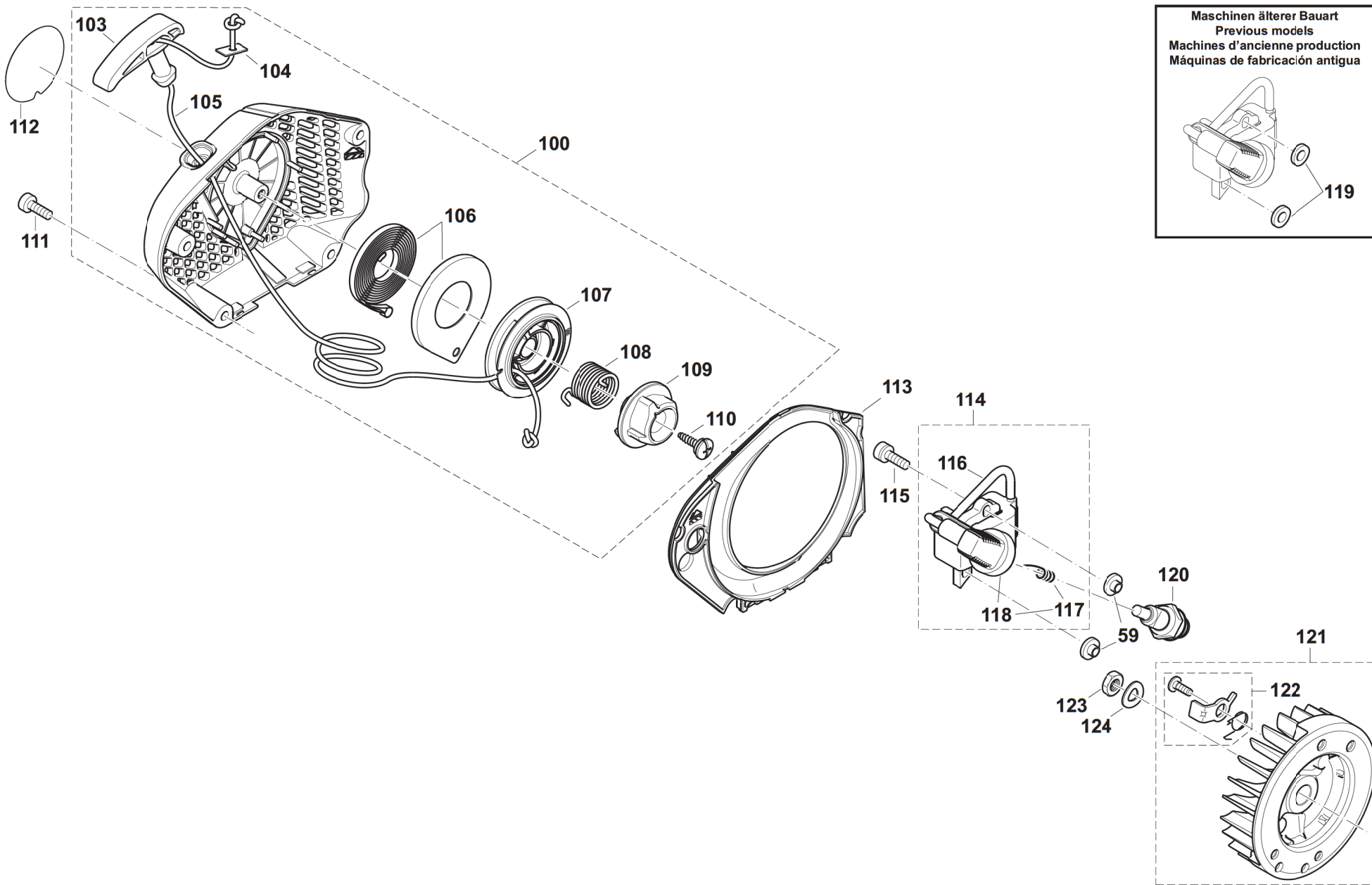

DCS3500, DCS3501, DCS4300, DCS4300 (RUS),
DCS4301, MDE350, MDE354, MDE430, MDE435,
MEA3500M, MEA3500MR, MEA3500L, MEA3500LR,
MEA4300L, MEA4300LR, MEA4300G, MEA4300GR,
EA3500F, EA3501F, EA4300F, EA4301F, CL350, CL430

4

Zündelektronik, Anwerfvorrichtung
Ignition electronics, starter
Allumage électronique, dispositif de démarrage
Bobina encendido, dispositivo de arranque



Seite / Page	Pos.	DCS3500	DCS3501	DCS4300	DCS4300 (RUS)	DCS4301	MDE350	MDE354	MDE430	MDE435	MEA3500M	MEA3500MR	MEA3500L	MEA3500LR	MEA4300L	MEA4300LR	MEA4300G	MEA4300GR	EA3500F	EA3501F	EA4300F	EA4301F	CL350	CL430	Teil-Nr. Part No. No. de pièce No. de pieza	Hinweise Notes Renseign. Nota	Bezeichnung	Spezifikation Specification	Description	Désignation	Denominación		
4	59	2	2	2	2	2	2	2	2	2	2	2	2	2	2	2	2	2	2	2	2	2	2	2	2	195 143 030	106000 =>	ISOLIERSCHEIBE	black	ISOLATING WASHER	RONDELLE	ARANDELA	
4	100											1	1	1	1	1	1	1						1	1	195 160 100		EASY STARTER KPL. ROT		STARTER ASSY. RED	DISPOS. DE DÉMARRAGE CPL.	DISPOS. DE ARRANQUE CPL. ROJO	
4	100	1	1	1	1	1	1	1	1	1	1		1	1	1	1	1	1	1	1	1	1	1	1		195 160 600		EASY STARTER KPL. BLAU		STARTER ASSY. BLUE	DISPOS. DE DÉMARRAGE CPL.	DISPOS. DE ARRANQUE CPL. AZUL	
4	103	1	1	1	1	1	1	1	1	1	1	1	1	1	1	1	1	1	1	1	1	1	1	1	1	195 160 070		ANWERFGRIF		STARTER GRIP	POIGNÉE DE LANCEMENT	TIRADOR DE ARRANQUE	
4	104	1	1	1	1	1	1	1	1	1	1	1	1	1	1	1	1	1	1	1	1	1	1	1	1	195 160 080		SCHEIBE		WASHER	RONDELLE	ARANDELA	
4	105	1	1	1	1	1	1	1	1	1	1	1	1	1	1	1	1	1	1	1	1	1	1	1	1	985 000 150	ACC.	ANWERFSEIL	ø 3 x 100 m	STARTER ROPE	CÂBLE	CORDÓN DE ARRANQUE	
4	105	1	1	1	1	1	1	1	1	1	1	1	1	1	1	1	1	1	1	1	1	1	1	1	1	021 164 010		ANWERFSEIL	ø 3 x 900 mm	STARTER ROPE	CÂBLE	CORDÓN DE ARRANQUE	
4	106	1	1	1	1	1	1	1	1	1	1	1	1	1	1	1	1	1	1	1	1	1	1	1	1	195 160 110		STARTERFEDER		REWIND SPRING	RESSORT DE RAPPEL	RESORTE RETENCIÓN	
4	107	1	1	1	1	1	1	1	1	1	1	1	1	1	1	1	1	1	1	1	1	1	1	1	1	195 160 040		SEILTROMMEL		CABLE DRUM CPL.	TAMBOUR DE CÂBLE CPL.	TAMBOUR PARA CORDÓN CPL.	
4	108	1	1	1	1	1	1	1	1	1	1	1	1	1	1	1	1	1	1	1	1	1	1	1	1	195 160 030		FEDER		SPRING	RESSORT	MUELLE	
4	109	1	1	1	1	1	1	1	1	1	1	1	1	1	1	1	1	1	1	1	1	1	1	1	1	195 160 020		MITNEHMER		STARTER WHEEL	ROUE DÉCLENCEUR	RUEDA DE ARRANQUE	
4	110	1	1	1	1	1	1	1	1	1	1	1	1	1	1	1	1	1	1	1	1	1	1	1	1	195 160 010		SCHRAUBE		SCREW	VIS	TORNILLO	
4	111	4	4	4	4	4	4	4	4	4	4	4	4	4	4	4	4	4	4	4	4	4	4	4	4	4	908 005 165		SCHRAUBE INNEN6RD ZK	M5x16	H.L. SOCKET HEAD BOLT	VIS	TORNILLO
4	112	1																								980 115 163		AUFKLEBER VENTILATORGEHÄUS E	DCS3500	LABEL	PLAQUE	CALCOMANIA	
4	112		1																							980 115 421		AUFKLEBER VENTILATORGEHÄUS E	DCS3501	LABEL	PLAQUE	CALCOMANIA	
4	112																		1							980 115 689		AUFKLEBER VENTILATORGEHÄUS E	EA3500F KAT	LABEL	PLAQUE	CALCOMANIA	
4	112																			1						980 115 688		AUFKLEBER VENTILATORGEHÄUS E	EA3501F	LABEL	PLAQUE	CALCOMANIA	
4	112			1	1																					980 115 164		AUFKLEBER VENTILATORGEHÄUS E	DCS4300	LABEL	PLAQUE	CALCOMANIA	

DCS3500, DCS3501, DCS4300, DCS4300 (RUS),
DCS4301, MDE350, MDE354, MDE430, MDE435,
MEA3500M, MEA3500MR, MEA3500L, MEA3500LR,
MEA4300L, MEA4300LR, MEA4300G, MEA4300GR,
EA3500F, EA3501F, EA4300F, EA4301F, CL350, CL430

4

Zündelektronik, Anwerfvorrichtung
Ignition electronics, starter
Allumage électronique, dispositif de démarrage
Bobina encendido, dispositivo de arranque

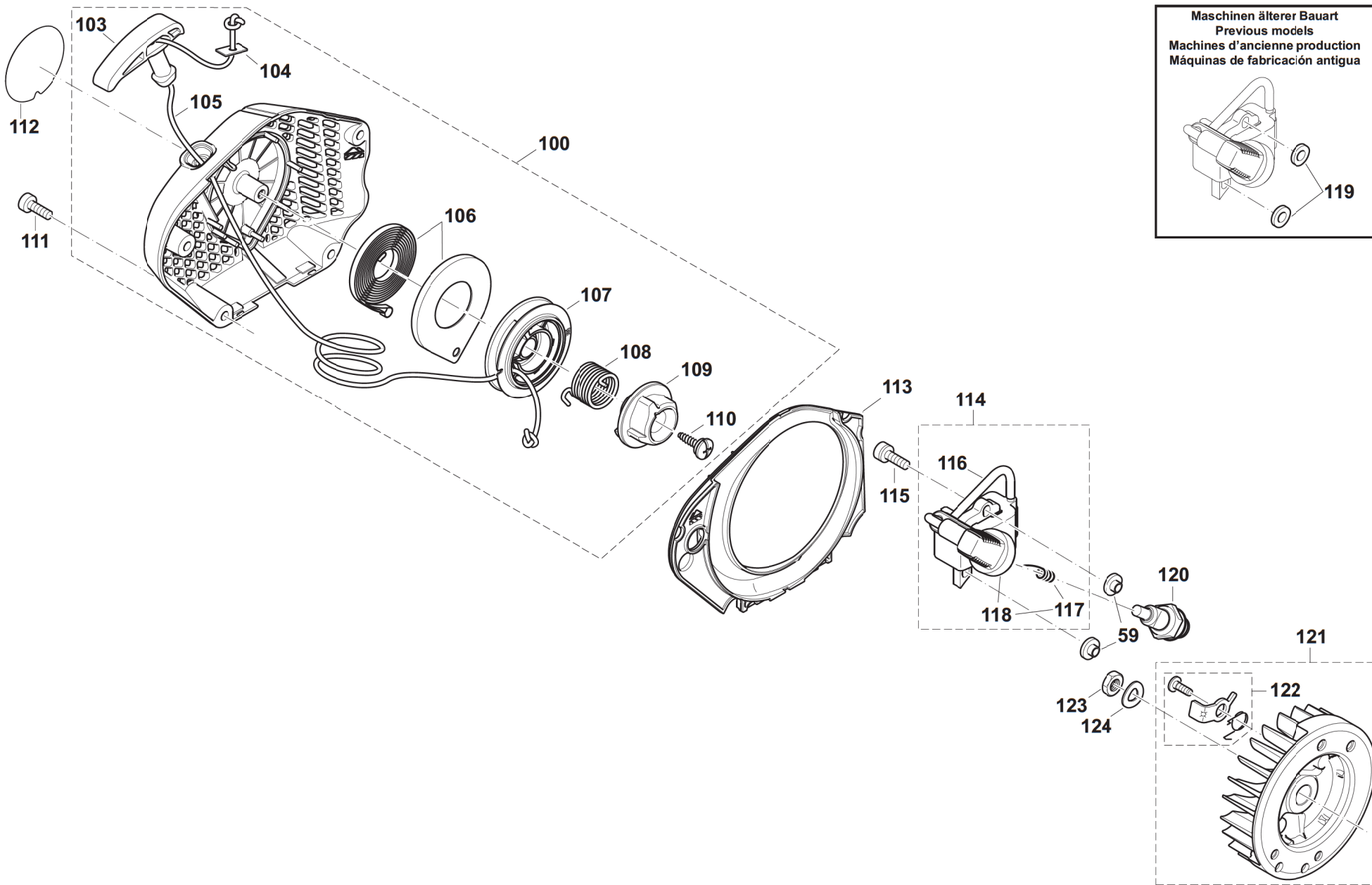

DCS3500, DCS3501, DCS4300, DCS4300 (RUS),
DCS4301, MDE350, MDE354, MDE430, MDE435,
MEA3500M, MEA3500MR, MEA3500L, MEA3500LR,
MEA4300L, MEA4300LR, MEA4300G, MEA4300GR,
EA3500F, EA3501F, EA4300F, EA4301F, CL350, CL430

4

Zündelektronik, Anwerfvorrichtung
Ignition electronics, starter
Allumage électronique, dispositif de démarrage
Bobina encendido, dispositivo de arranque



Seite / Page	Pos.	DCS3500	DCS3501	DCS4300	DCS4300 (RUS)	DCS4301	MDE350	MDE354	MDE430	MDE435	MEA3500M	MEA3500MR	MEA3500L	MEA3500LR	MEA4300L	MEA4300LR	MEA4300G	MEA4300GR	EA3500F	EA3501F	EA4300F	EA4301F	CL350	CL430	Teil-Nr. Part No. No. de pièce No. de pieza	Hinweise Notes Renseign. Nota	Bezeichnung	Spezifikation Specification	Description	Désignation	Denominación
4	112					1																			980 115 422		AUFKLEBER VENTILATORGEHÄU E	DCS4301	LABEL	PLAQUE	CALCOMANIA
4	112																				1				980 115 740		AUFKLEBER VENTILATORGEHÄU E	EA4300F KAT	LABEL	PLAQUE	CALCOMANIA
4	112																								980 115 690		AUFKLEBER VENTILATORGEHÄU E	EA4301F	LABEL	PLAQUE	CALCOMANIA
4	112						1																		980 115 465		AUFKLEBER VENTILATORGEHÄU E	MDE350	LABEL	PLAQUE	CALCOMANIA
4	112							1																	980 115 512		AUFKLEBER VENTILATORGEHÄU E	MDE354	LABEL	PLAQUE	CALCOMANIA
4	112								1																980 115 466		AUFKLEBER VENTILATORGEHÄU E	MDE430	LABEL	PLAQUE	CALCOMANIA
4	112									1															980 115 511		AUFKLEBER VENTILATORGEHÄU E	MDE435	LABEL	PLAQUE	CALCOMANIA
4	112										1														980 115 561		AUFKLEBER VENTILATORGEHÄU E	MEA3500M	LABEL	PLAQUE	CALCOMANIA
4	112											1													980 115 562		AUFKLEBER VENTILATORGEHÄU E	MEA3500L	LABEL	PLAQUE	CALCOMANIA
4	112												1												980 115 563		AUFKLEBER VENTILATORGEHÄU E	MEA4300L	LABEL	PLAQUE	CALCOMANIA
4	112															1									980 115 564		AUFKLEBER VENTILATORGEHÄU E	MEA4300G	LABEL	PLAQUE	CALCOMANIA
4	112										1														980 115 865		AUFKLEBER VENTILATORGEHÄU E	MEA3500MR	LABEL	PLAQUE	CALCOMANIA
4	112												1												980 115 866		AUFKLEBER VENTILATORGEHÄU E	MEA3500LR	LABEL	PLAQUE	CALCOMANIA
4	112													1											980 115 867		AUFKLEBER VENTILATORGEHÄU E	MEA4300LR	LABEL	PLAQUE	CALCOMANIA

DCS3500, DCS3501, DCS4300, DCS4300 (RUS),
DCS4301, MDE350, MDE354, MDE430, MDE435,
MEA3500M, MEA3500MR, MEA3500L, MEA3500LR,
MEA4300L, MEA4300LR, MEA4300G, MEA4300GR,
EA3500F, EA3501F, EA4300F, EA4301F, CL350, CL430

4

Zündelektronik, Anwerfvorrichtung
Ignition electronics, starter
Allumage électronique, dispositif de démarrage
Bobina encendido, dispositivo de arranque

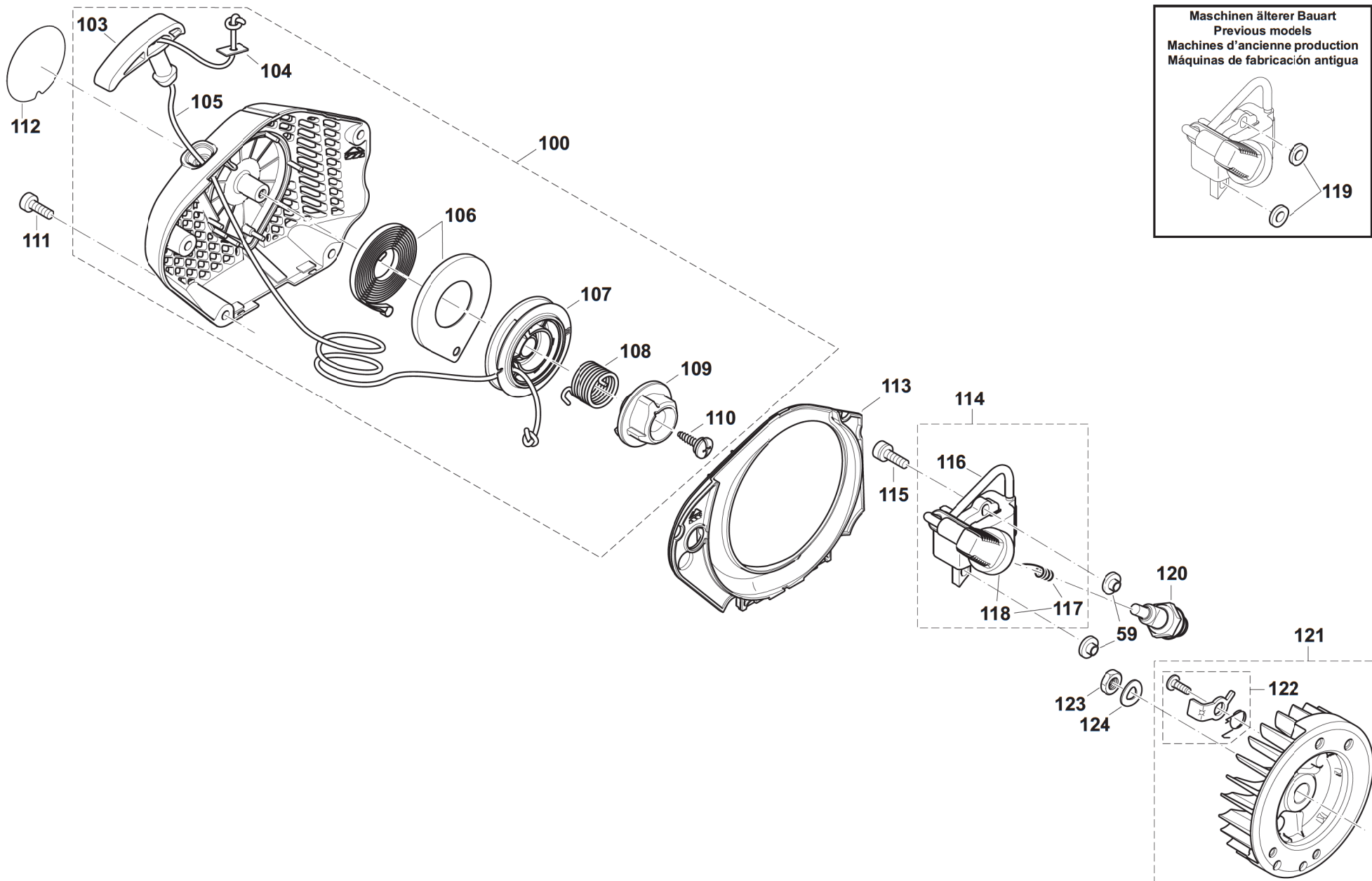

Maschinen älterer Bauart
Previous models
Machines d'ancienne production
Máquinas de fabricación antigua

DCS3500, DCS3501, DCS4300, DCS4300 (RUS),
DCS4301, MDE350, MDE354, MDE430, MDE435,
MEA3500M, MEA3500MR, MEA3500L, MEA3500LR,
MEA4300L, MEA4300LR, MEA4300G, MEA4300GR,
EA3500F, EA3501F, EA4300F, EA4301F, CL350, CL430

4

Zündelektronik, Anwerfvorrichtung
Ignition electronics, starter
Allumage électronique, dispositif de démarrage
Bobina encendido, dispositivo de arranque



Seite / Page	Pos.	DCS3500	DCS3501	DCS4300	DCS4300 (RUS)	DCS4301	MDE350	MDE354	MDE430	MDE435	MEA3500M	MEA3500MR	MEA3500L	MEA3500LR	MEA4300L	MEA4300LR	MEA4300G	MEA4300GR	EA3500F	EA3501F	EA4300F	EA4301F	CL350	CL430	Teil-Nr. Part No. No. de pièce No. de pieza	Hinweise Notes Renseign. Nota	Bezeichnung	Spezifikation Specification	Description	Désignation	Denominación
4	112																	1							980 115 868		AUFKLEBER VENTILATORGEHÄU E	MEA4300GR	LABEL	PLAQUE	CALCOMANIA
4	112																						1		980 115 566		AUFKLEBER VENTILATORGEHÄU E	CL350	LABEL	PLAQUE	CALCOMANIA
4	112																						1		980 115 567		AUFKLEBER VENTILATORGEHÄU E	CL430	LABEL	PLAQUE	CALCOMANIA
4	113	1	1	1	1	1	1	1	1	1	1	1	1	1	1	1	1	1	1	1	1	1	1	1	195 118 040		LUFTFÜHRUNG		AIR GUIDE PLATE	GUIDE D'AIR	CONDUCTO DE AIRE
4	114	1	1	1	1	1	1	1	1	1	1	1	1	1	1	1	1	1	1	1	1	1	1	1	195 143 200		ZÜNDSPULE KPL.		IGNITION COIL CPL.	BOBINE D ALLUMAGE CPL.	BOBINA DE ENCENDIDO CPL.
4	115	2	2	2	2	2	2	2	2	2	2	2	2	2	2	2	2	2	2	2	2	2	2	2	908 805 205		ZYLINDERSCHRAUBE MIT SPANNSCHEIBE	M5X20	SCREW	VIS	TORNILLO
4	116	m	m	m	m	m	m	m	m	m	m	m	m	m	m	m	m	m	m	m	m	m	m	m	970 502 110		ISOLIERSCHLAUCH	A6X0,5 100 mm	ISOLATING HOSE	TUYAU ISOLANT	MANGO AISLANTE
4	117	1	1	1	1	1	1	1	1	1	1	1	1	1	1	1	1	1	1	1	1	1	1	1	965 604 180		FEDER		SPRING	RESSORT	MUELLE
4	118	1	1	1	1	1	1	1	1	1	1	1	1	1	1	1	1	1	1	1	1	1	1	1	957 604 220		ZÜNDKERZENSTECK ER KPL.		PLUG CAP CPL.	FICHE DE BOUGIE CPL.	TAPA DE BUJIA CPL.
4	119	2	2	2		2	2	2	2	2															195 143 020	=> 105999	ISO-SCHEIBE, BRAUN		WASHER, BROWN	RONDELLE, BRUN	ARANDELA, MARRÓN
4	120	1	1	1		1	1	1	1	1															965 603 021		ZÜNDKERZE		SPARK PLUG	BOUGIE	BUJÍA
4	120				1						1	1	1	1	1	1	1	1	1	1	1	1	1	1	965 603 040		ZÜNDKERZE	NGK CMR7A-5	SPARK PLUG	BOUGIE	BUJIA
4	121	1	1	1	1	1	1	1	1	1	1	1	1	1	1	1	1	1	1	1	1	1	1	1	195 141 103		POLRAD KPL.		FLYWHEEL CPL.	ROUE POLAIRE CPL.	VOLANTE ENCEND. CPL.
4	122	2	2	2	2	2	2	2	2	2	2	2	2	2	2	2	2	2	2	2	2	2	2	2	195 166 100		ANWERFKLINKE KPL.		STARTER RATCHET CPL.	CLIQUET CPL.	TRINQUETE ARRANQUE CPL.
4	123	1	1	1	1	1	1	1	1	1	1	1	1	1	1	1	1	1	1	1	1	1	1	1	920 308 024		6KT-MUTTER	M8x1	HEXAGONAL NUT	ECROU HEXAGONAL	TUERCA HEXAGONAL
4	124	1	1	1	1	1	1	1	1	1	1	1	1	1	1	1	1	1	1	1	1	1	1	1	926 208 001		FEDERSCHEIBE	B8	SPRING WASHER	RONDELLE ÉLASTIQUE	DISCO AMORTIGUADOR

DCS3500, DCS3501, DCS4300, DCS4300 (RUS),
 DCS4301, MDE350, MDE354, MDE430, MDE435,
 MEA3500M, MEA3500MR, MEA3500L, MEA3500LR,
 MEA4300L, MEA4300LR, MEA4300G, MEA4300GR,
 EA3500F, EA3501F, EA4300F, EA4301F, CL350, CL430

5

Ölpumpe, Kupplung, Kettenbremse
 Oil pump, clutch, chain brake
 Pompe à huile, embrayage, frein de chaîne
 Bomba de aceite, embrague, freno de cadena

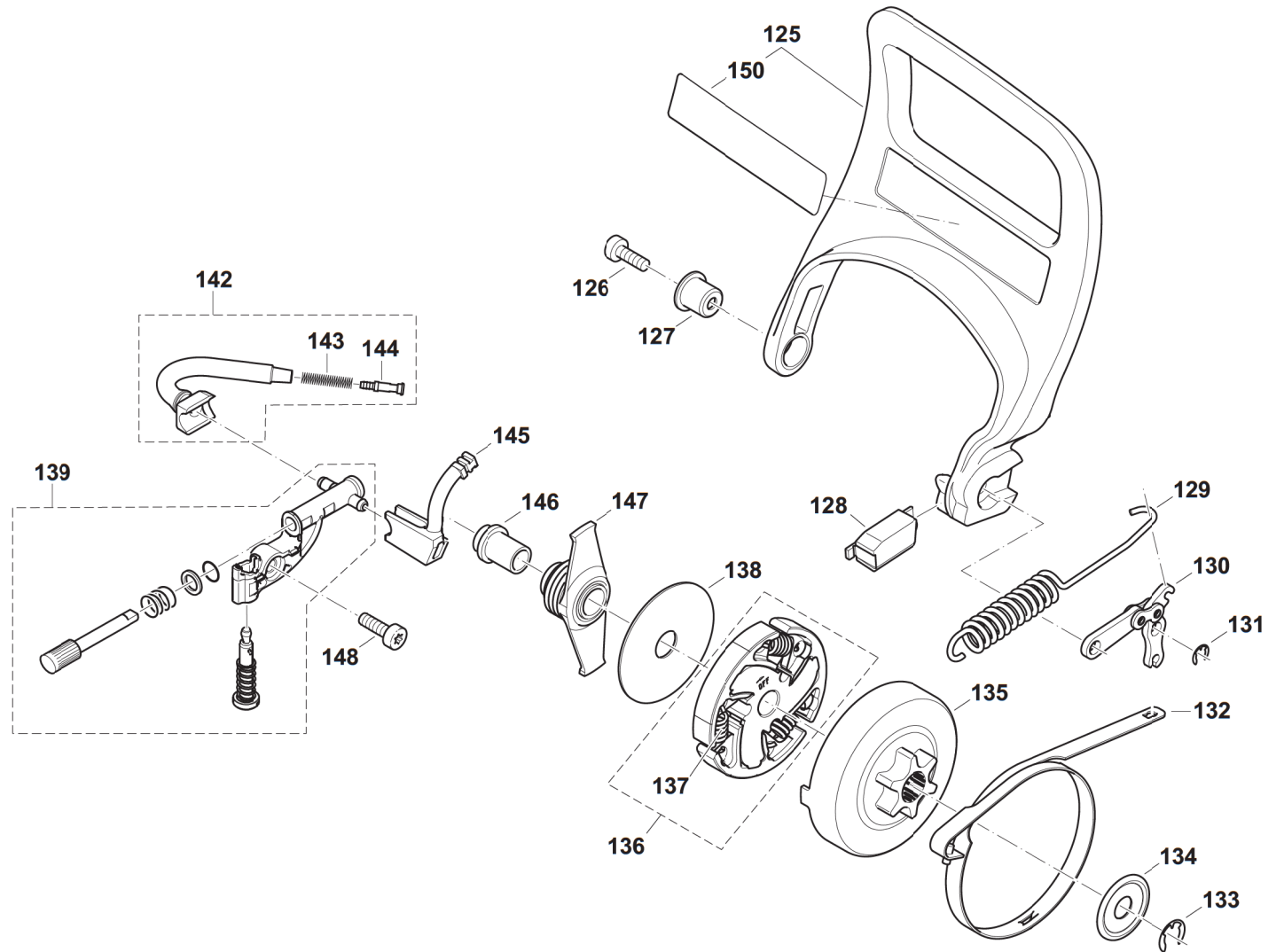
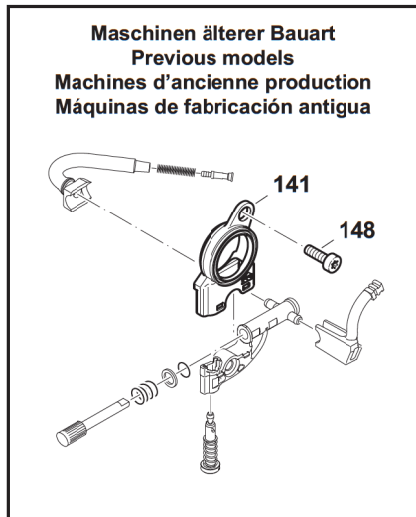

DCS3500, DCS3501, DCS4300, DCS4300 (RUS),
DCS4301, MDE350, MDE354, MDE430, MDE435,
MEA3500M, MEA3500MR, MEA3500L, MEA3500LR,
MEA4300L, MEA4300LR, MEA4300G, MEA4300GR,
EA3500F, EA3501F, EA4300F, EA4301F, CL350, CL430

5

Ölpumpe, Kupplung, Kettenbremse
Oil pump, clutch, chain brake
Pompe à huile, embrayage, frein de chaîne
Bomba de aceite, engrague, freno de cadena



Seite / Page	Pos.	DCS3500	DCS3501	DCS4300	DCS4300 (RUS)	DCS4301	MDE350	MDE354	MDE430	MDE435	MEA3500M	MEA3500MR	MEA3500L	MEA3500LR	MEA4300L	MEA4300LR	MEA4300G	MEA4300GR	EA3500F	EA3501F	EA4300F	EA4301F	CL350	CL430	Teil-Nr. Part No. No. de pièce No. de pieza	Hinweise Notes Renseign. Nota	Bezeichnung	Spezifikation Specification	Description	Désignation	Denominación	
5	125	1	1	1	1	1	1	1	1	1	1	1	1	1	1	1	1	1	1	1	1	1	1	1	1	195 213 500		HANDSCHUTZ KPL.		HAND GUARD CPL.	PROTÈGE-MAIN CPL.	PROTECTOR DE MANO CPL.
5	126	1	1	1	1	1	1	1	1	1	1	1	1	1	1	1	1	1	1	1	1	1	1	1	1	908 005 165		SCHRAUBE INNEN6RD ZK	M5x16	H.L. SOCKET HEAD BOLT	VIS	TORNILLO
5	127	1	1	1	1	1	1	1	1	1	1	1	1	1	1	1	1	1	1	1	1	1	1	1	1	181 213 320		BUCHSE FÜR HANDSCHUTZ		BUSHING	DOUILLE	CASQUILLO
5	128	1	1	1	1	1	1	1	1	1	1	1	1	1	1	1	1	1	1	1	1	1	1	1	1	181 213 170		KULISSE FÜR HANDSCHUTZ KPL.		HANDGUARD GUIDE, CPL.	COULISSE P. PROTÈGE-MAINS CPL.	CULISA P. PROTECCIÓN DE MANOS CPL.
5	129	1	1	1	1	1	1	1	1	1	1	1	1	1	1	1	1	1	1	1	1	1	1	1	1	181 213 023		ZUGFEDER		TENSION SPRING	RESSORT DE TRACTION	MUELLE DE TRACCIÓN
5	130	1	1	1	1	1	1	1	1	1	1	1	1	1	1	1	1	1	1	1	1	1	1	1	1	181 213 100		BREMSMECHANI K KPL.		BRAKING MECHANISM	MECANISME DE FREINAGE	MECANISMO DE FRENO
5	131	1	1	1	1	1	1	1	1	1	1	1	1	1	1	1	1	1	1	1	1	1	1	1	1	927 304 000		SICHERUNGSSCH EIBE		SAFETY WASHER	RONDELLE SÉCURITÉ	ARANDELA SEGURIDAD
5	132	1	1	1	1	1	1	1	1	1	1	1	1	1	1	1	1	1	1	1	1	1	1	1	1	181 213 011		BREMSBAND		BRAKE SPRING	RESSORT DE FREIN	CINTA DE FRENO
5	133	1	1	1	1	1	1	1	1	1	1	1	1	1	1	1	1	1	1	1	1	1	1	1	1	927 408 000		SICHERUNGSSCH EIBE	D=8X1,3	WASHER	RONDELLE	ARANDELA
5	134	1	1	1	1	1	1	1	1	1	1	1	1	1	1	1	1	1	1	1	1	1	1	1	1	181 224 081		TOPFSCHEIBE		DISC	DISQUE	ARANDELA
5	135	1	1	1	1	1	1	1	1	1	1	1	1	1	1	1	1	1	1	1	1	1	1	1	1	195 223 311		KUPPLUNGSTRO MMEL KPL.	3/8", Z=6	CLUTCH DRUM CPL.	TAMBOUR CPL.	TAMBOR CPL.
5	135	1	1	1	1	1	1	1	1	1	1	1	1	1	1	1	1	1	1	1	1	1	1	1	1	181 223 311		KUPPLUNGSTRO MMEL KPL.	.325", Z=7	CLUTCH DRUM CPL.	TAMBOUR CPL.	TAMBOR CPL.
5	136	1	1	1	1	1	1	1	1	1	1	1	1	1	1	1	1	1	1	1	1	1	1	1	1	175 180 101		KUPPLUNG KPL.		CLUTCH ASSY.	EMBRAYAGE CPL.	EMBRAGUE CPL.
5	137	3	3	3	3	3	3	3	3	3	3	3	3	3	3	3	3	3	3	3	3	3	3	3	3	024 184 021		ZUGFEDER		SPRING	RESSORT	RESORTE
5	138	1	1	1	1	1	1	1	1	1	1	1	1	1	1	1	1	1	1	1	1	1	1	1	1	001 182 042		FÜHRUNGSSCHEI BE	44,5x1x12	DISC	DISQUE	DISCO
5	139	1	1	1	1	1	1	1	1	1	1	1	1	1	1	1	1	1	1	1	1	1	1	1	1	179 245 201		ÖLPUMPE KPL.		OIL PUMP CPL.	POMPE À HUILE CPL.	BOMBA DE ACEITE CPL.
5	141	1	1	1	1	1	1	1	1	1	1	1	1	1	1	1	1	1	1	1	1	1	1	1	1	195 245 140		ÖLPUMPENABDE CKUNG		OIL PUMP COVER	COUVERCLE DE POMPE À HUILE	TAPA DE BOMBA DE ACEITE
5	142	1	1	1	1	1	1	1	1	1	1	1	1	1	1	1	1	1	1	1	1	1	1	1	1	181 245 100		ÖLSAUGLEITUNG KPL.		SUCTION LINE	CONDUITE HUILE CPL.	TUBO ACEITE CPL.
5	143	1	1	1	1	1	1	1	1	1	1	1	1	1	1	1	1	1	1	1	1	1	1	1	1	021 245 060		DRUCKFEDER		SPRING	RESSORT	MUELLE
5	144	1	1	1	1	1	1	1	1	1	1	1	1	1	1	1	1	1	1	1	1	1	1	1	1	001 245 020		NIPPEL		HOSE STEM	TETON DE TUYAU	BOQUILLA DE TUBO
5	145	1	1	1	1	1	1	1	1	1	1	1	1	1	1	1	1	1	1	1	1	1	1	1	1	181 245 120		ÖLDRUCKLEITUN G		PRESSURE LINE	CONDUITE HUILE	TUBO ACEITE

DCS3500, DCS3501, DCS4300, DCS4300 (RUS),
 DCS4301, MDE350, MDE354, MDE430, MDE435,
 MEA3500M, MEA3500MR, MEA3500L, MEA3500LR,
 MEA4300L, MEA4300LR, MEA4300G, MEA4300GR,
 EA3500F, EA3501F, EA4300F, EA4301F, CL350, CL430

5

Ölpumpe, Kupplung, Kettenbremse
 Oil pump, clutch, chain brake
 Pompe à huile, embrayage, frein de chaîne
 Bomba de aceite, engrague, freno de cadena

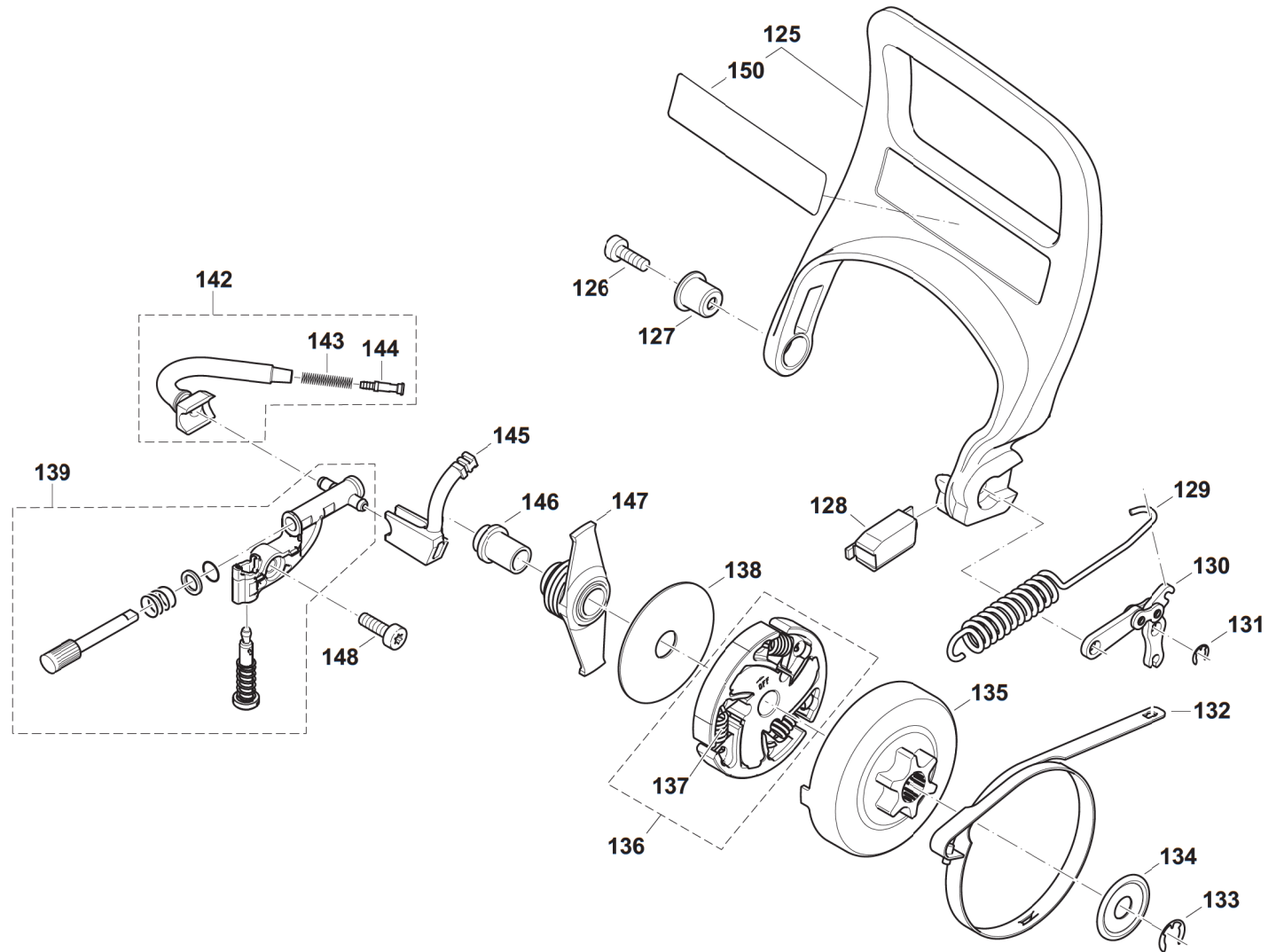
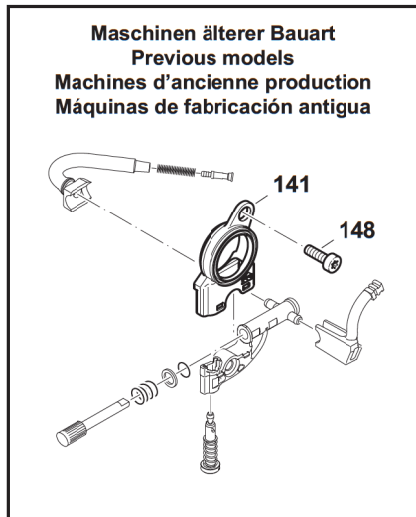

DCS3500, DCS3501, DCS4300, DCS4300 (RUS),
DCS4301, MDE350, MDE354, MDE430, MDE435,
MEA3500M, MEA3500MR, MEA3500L, MEA3500LR,
MEA4300L, MEA4300LR, MEA4300G, MEA4300GR,
EA3500F, EA3501F, EA4300F, EA4301F, CL350, CL430

5

Ölpumpe, Kupplung, Kettenbremse
Oil pump, clutch, chain brake
Pompe à huile, embrayage, frein de chaîne
Bomba de aceite, engrague, freno de cadena



Seite / Page	Pos.	DCS3500	DCS3501	DCS4300	DCS4300 (RUS)	DCS4301	MDE350	MDE354	MDE430	MDE435	MEA3500M	MEA3500MR	MEA3500L	MEA3500LR	MEA4300L	MEA4300LR	MEA4300G	MEA4300GR	EA3500F	EA3501F	EA4300F	EA4301F	CL350	CL430	Teil-Nr. Part No. No. de pièce No. de pieza	Hinweise Notes Renseign. Nota	Bezeichnung	Spezifikation Specification	Description	Désignation	Denominación	
5	146	1	1	1	1	1	1	1	1	1	1	1	1	1	1	1	1	1	1	1	1	1	1	1	1	195 245 010		BUCHSE ÖLPUMPENANTRI EB		BUSHING	DOUILLE	CASQUILLO
5	147	1	1	1	1	1	1	1	1	1	1	1	1	1	1	1	1	1	1	1	1	1	1	1	181 245 090		ÖLPUMPENANTRI EB		PUMP DRIVE	LE COMMANDE DE POMPE	PROPULSOR DE LA BOMBA	
5	148	2	2	2	2	2	2	2	2	2	1	1	1	1	1	1	1	1	2	2	2	2	1	1	908 005 165		SCHRAUBE INNEN6RD ZK	M5x16	H.L. SOCKET HEAD BOLT	VIS	TORNILLO	
5	150	1	1	1	1	1													1	1	1	1			980 114 237		SCHILD HANDSCHUTZ		LABEL	PLAQUE	CALCOMANIA	
5	150																		1	1	1	1			980 115 808		SCHILD HANDSCHUTZ	US WARNING SPARKS	LABEL	PLAQUE	CALCOMANIA	
5	150						1	1	1	1	1	1	1	1	1	1	1	1					1	1	980 115 200		SCHILD HANDSCHUTZ	J	LABEL	PLAQUE	CALCOMANIA	

DCS3500, DCS3501, DCS4300, DCS4300 (RUS),
DCS4301, MDE350, MDE354, MDE430, MDE435,
MEA3500M, MEA3500MR, MEA3500L, MEA3500LR,
MEA4300L, MEA4300LR, MEA4300G, MEA4300GR,
EA3500F, EA3501F, EA4300F, EA4301F, CL350, CL430

6

Kettenradschutz, Kettenspanner
Sprocket guard, chain tensioner
Protège-pignon, tendeur de chaîne
Protector de piñon, tensor de la cadena

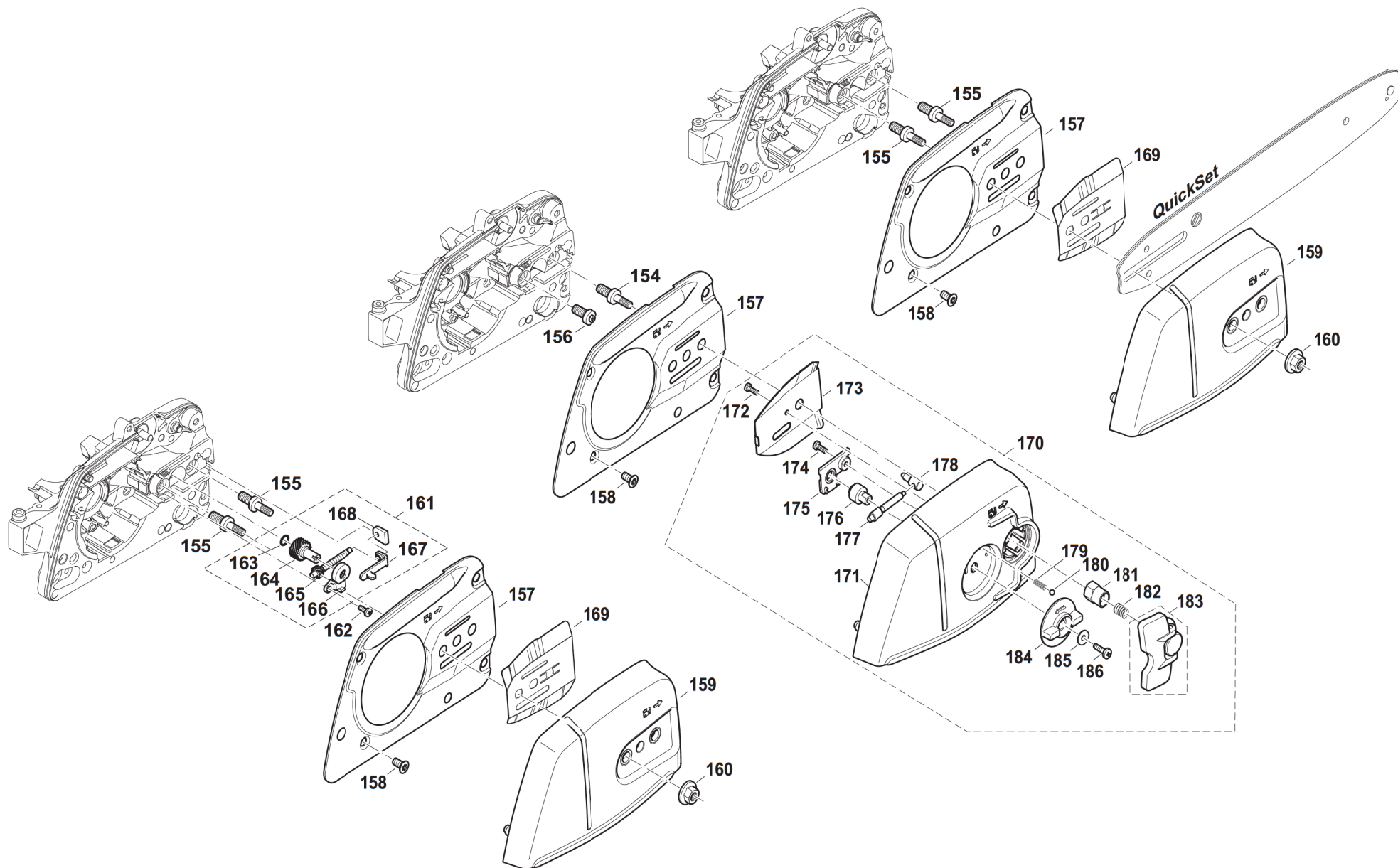

DCS3500, DCS3501, DCS4300, DCS4300 (RUS),
DCS4301, MDE350, MDE354, MDE430, MDE435,
MEA3500M, MEA3500MR, MEA3500L, MEA3500LR,
MEA4300L, MEA4300LR, MEA4300G, MEA4300GR,
EA3500F, EA3501F, EA4300F, EA4301F, CL350, CL430

6

Kettenradschutz, Kettenspanner
Sprocket guard, chain tensioner
Protège-pignon, tendeur de chaîne
Protector de piñon, tensor de la cadena



Seite / Page	Pos.	DCS3500	DCS3501	DCS4300	DCS4300 (RUS)	DCS4301	MDE350	MDE354	MDE430	MDE435	MEA3500M	MEA3500MR	MEA3500L	MEA3500LR	MEA4300L	MEA4300LR	MEA4300G	MEA4300GR	EA3500F	EA3501F	EA4300F	EA4301F	CL350	CL430	Teil-Nr. Part No. No. de pièce No. de pieza	Hinweise Notes Renseign. Nota	Bezeichnung	Spezifikation Specification	Description	Désignation	Denominación	
6	154	1	1	1		1		1		1			1	1			1	1	1	1	1	1			195 232 020		SCHIENENBOLZEN MIT BUND	M8x1	BOLT	BOULON	BULÓN	
6	155	2	2	2	2	2	2	2	2	2	2	2	2	2	2	2	2	2	2	2	2	2	2	2	195 232 010		SCHIENENBOLZEN MIT BUND	M8	BOLT	BOULON	BULÓN	
6	156	1	1	1		1		1		1			1	1			1	1	1	1	1	1			195 232 040		SCHIENENSTIFT	M8	BOLT	BOULON	BULÓN	
6	157	1	1	1	1	1	1	1	1	1	1	1	1	1	1	1	1	1	1	1	1	1	1	1	195 213 190		ABDECKUNG KETTENBREMSE		COVER	COUVERCLE	CUBIERTA	
6	158	2	2	2	2	2	2	2	2	2	2	2	2	2	2	2	2	2	2	2	2	2	2	2	908 105 126		SCHRAUBE	M5x12	SCREW	VIS	TORNILLO	
6	159											1		1		1		1						1	1	195 213 101		KETTENRADSCHUT Z KPL. ROT		SPROCKET GUARD CPL. RED	PROTÈGE-PIGNON CPL. ROUGE	PROTECTOR DE PIÑON CPL. ROJO
6	159	1	1	1	1	1	1	1	1	1	1		1		1		1		1	1	1	1			195 213 601		KETTENRADSCHUT Z KPL. BLAU		SPROCKET GUARD CPL. BLUE	PROTÈGE-PIGNON CPL. BLEU	PROTECTOR DE PIÑON CPL. AZUL	
6	160	2	2	2	2	2	2	2	2	2	2	2	2	2	2	2	2	2	2	2	2	2	2	2	923 208 004		6KT-MUTTER	M8	HAXAGONAL NUT	ECROU HEXAGONAL	TUERCA HEXAGONAL	
6	161	1	1	1	1	1	1	1	1	1	1	1	1	1	1	1	1	1	1	1	1	1	1	1	195 213 300		KETTENSPANNER KPL.	PROFI	CHAIN TENSIONER CPL.	TENDEUR DE CHAÎNE CPL.	SENSOR DE LA CADENA CPL.	
6	162	1	1	1	1	1	1	1	1	1	1	1	1	1	1	1	1	1	1	1	1	1	1	1	915 535 100		SCHRAUBE	3,5x9,5	SCREW	VIS	TORNILLO	
6	163	1	1	1	1	1	1	1	1	1	1	1	1	1	1	1	1	1	1	1	1	1	1	1	963 207 020		O-RING	7X2	PACKING RING	BAGUE-JOINT	ANILLIO DE GUARNICION	
6	164	1	1	1	1	1	1	1	1	1	1	1	1	1	1	1	1	1	1	1	1	1	1	1	181 213 250		EINSTELLSCHRAUB E	PROFI	ADJUSTING SCREW	VIS DE REGLAGE	TORNILLO DE AJUSTE	
6	165	1	1	1	1	1	1	1	1	1	1	1	1	1	1	1	1	1	1	1	1	1	1	1	181 213 230		KETTENSPANNSCH RAUBE	PROFI	TENSIONING SCREW	VIUS DE TENSION	TORNILLO DE TENSION	
6	166	1	1	1	1	1	1	1	1	1	1	1	1	1	1	1	1	1	1	1	1	1	1	1	181 213 270		GETRIEBEABDECK UNG	PROFI	TRANSMISSION COVER	REVÊTEMENT D' ENGRENAGES	CUBIERTA DE ENGRANAJES	
6	167	1	1	1	1	1	1	1	1	1	1	1	1	1	1	1	1	1	1	1	1	1	1	1	195 213 241		SPANNSCHLITTEN		TENSION SLIDE	COULISSEAU DE SERRAGE	CARRO DE TENSADO	
6	168	1	1	1	1	1	1	1	1	1	1	1	1	1	1	1	1	1	1	1	1	1	1	1	181 213 260		SPANNSCHRAUBEN LAGER		TENSIONING SCREW BEARING	PALIER DE LA VIS DE TENSION	SOPORTE DEL TORNILLO TENSOR	
6	169	1	1	1	1	1	1	1	1	1	1	1	1	1	1	1	1	1	1	1	1	1	1	1	195 213 120		KETTENFÜHRUNGS BLECH		GUIDE PLATE	TÔLE DE GUIDAGE	CHAPA DE GUÍA	
6	170												1				1								195 213 150		KETTENRADSCHUT Z KPL. ROT	TLC	SPROCKET GUARD CPL., RED	PROTÈGE-PIGNON CPL. ROUGE	PROTECTOR DE PIÑON CPL. ROJO	
6	170	1	1	1	1	1		1		1						1		1	1	1	1				195 213 650		KETTENRADSCHUT Z KPL. BLAU	TLC	SPROCKET GUARD CPL., BLUE	PROTÈGE-PIGNON CPL. BLEU	PROTECTOR DE PIÑON CPL. AZUL	
6	171												1				1								195 213 311		KETTENRADSCHUT Z ROT	TLC	SPROCKET GUARD, RED	PROTÈGE-PIGNON ROUGE	PROTECTOR DE PIÑON ROJO	
6	171	1	1	1	1	1		1		1						1		1	1	1	1				195 213 621		KETTENRADSCHUT Z BLAU	TLC	SPROCKET GUARD, BLUE	PROTÈGE-PIGNON BLEU	PROTECTOR DE PIÑON AZUL	
6	172	1	1	1		1		1		1			1	1		1	1	1	1	1	1				915 735 100		SCHRAUBE	3,5x10	SCREW	VIS	TORNILLO	
6	173	1	1	1		1		1		1			1	1		1	1	1	1	1	1				195 213 320		KETTENFÜHRUNGS BLECH	TLC	GUIDE PLATE	TÔLE DE GUIDAGE	CHAPA DE GUÍA	

DCS3500, DCS3501, DCS4300, DCS4300 (RUS),
DCS4301, MDE350, MDE354, MDE430, MDE435,
MEA3500M, MEA3500MR, MEA3500L, MEA3500LR,
MEA4300L, MEA4300LR, MEA4300G, MEA4300GR,
EA3500F, EA3501F, EA4300F, EA4301F, CL350, CL430

6

Kettenradchutz, Kettenspanner
Sprocket guard, chain tensioner
Protège-pignon, tendeur de chaîne
Protector de piñon, tensor de la cadena

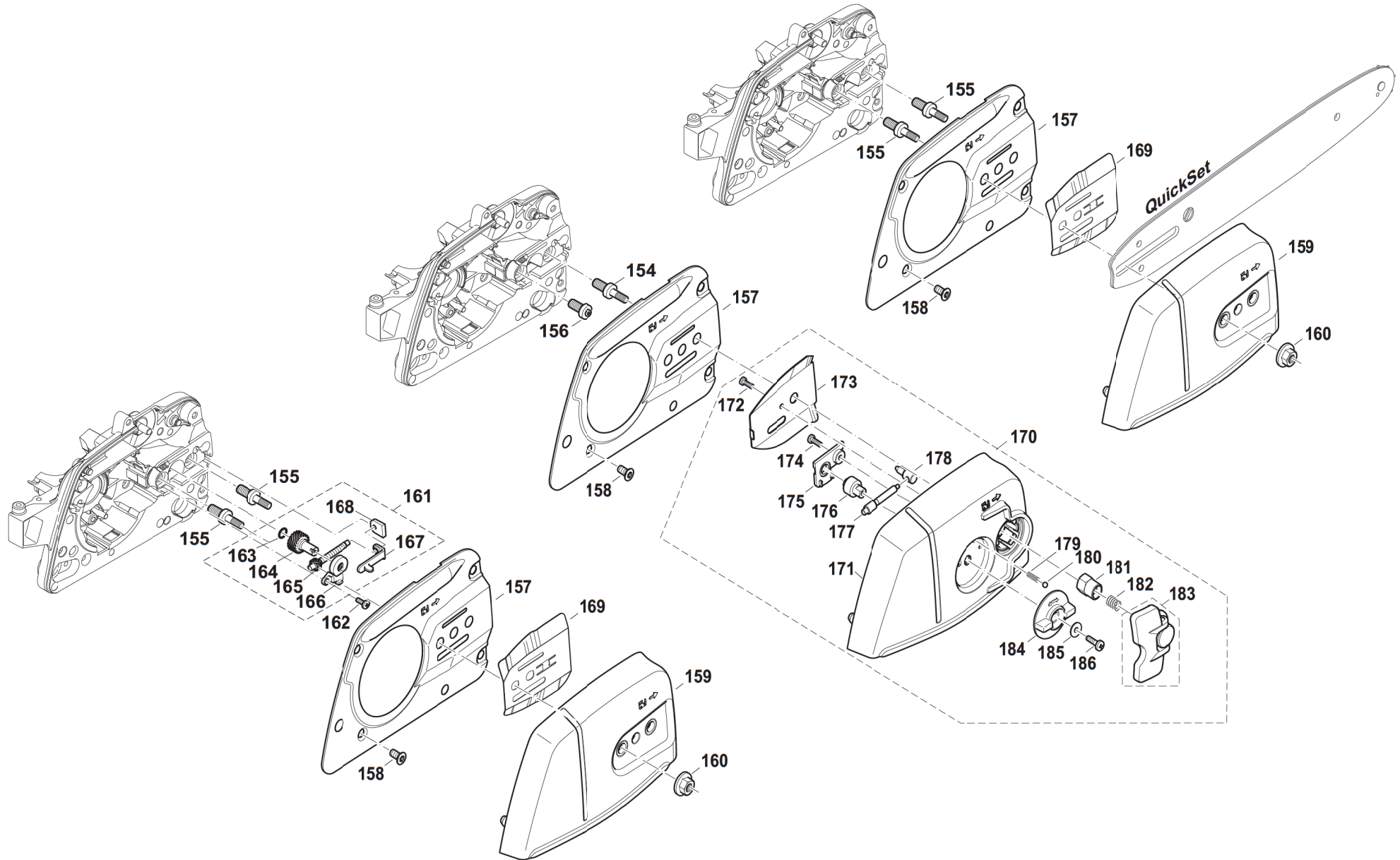

DCS3500, DCS3501, DCS4300, DCS4300 (RUS),
DCS4301, MDE350, MDE354, MDE430, MDE435,
MEA3500M, MEA3500MR, MEA3500L, MEA3500LR,
MEA4300L, MEA4300LR, MEA4300G, MEA4300GR,
EA3500F, EA3501F, EA4300F, EA4301F, CL350, CL430

6

Kettenradschutz, Kettenspanner
Sprocket guard, chain tensioner
Protège-pignon, tendeur de chaîne
Protector de piñon, tensor de la cadena



Seite / Page	Pos.	DCS3500	DCS3501	DCS4300	DCS4300 (RUS)	DCS4301	MDE350	MDE354	MDE430	MDE435	MEA3500M	MEA3500MR	MEA3500L	MEA3500LR	MEA4300L	MEA4300LR	MEA4300G	MEA4300GR	EA3500F	EA3501F	EA4300F	EA4301F	CL350	CL430	Teil-Nr. Part No. No. de pièce No. de pieza	Hinweise Notes Renseign. Nota	Bezeichnung	Spezifikation Specification	Description	Désignation	Denominación
6	174	1	1	1		1							1	1		1	1	1	1	1	1	1			915 735 100		SCHRAUBE	3,5x10	SCREW	VIS	TORNILLO
6	175	1	1	1		1	1	1					1	1		1	1	1	1	1	1	1			170 213 670		KETTENSANNABD ECKUNG		COVER	COUVERCLE	CUBIERTA
6	176	1	1	1		1	1	1					1	1		1	1	1	1	1	1	1			170 213 710		ANTRIEBSRAD TLC		DRIVE WHEEL	ROUE D'ENTRAÎNEMENT	RUEDA DE IMPULSION
6	177	1	1	1		1	1	1					1	1		1	1	1	1	1	1	1			170 213 650		SPANNSCHRAUBE		TENSIONING SCREW	VIS DE TENSION	TORNILLO DE TENSION
6	178	1	1	1		1	1	1					1	1		1	1	1	1	1	1	1			170 213 660		SPANNMUTTER		TENSIONING NUT	ECROU DE TENSION	TUERCA DE TENSION
6	179	1	1	1		1	1	1					1	1		1	1	1	1	1	1	1			170 213 690		FEDER F.STAHLKUGEL	4	SPRING	RESSORT	MUELLE
6	180	1	1	1		1	1	1					1	1		1	1	1	1	1	1	1			170 213 770		STAHLKUGEL	4	LOCKING BALL	BILLE D ARRÊT	BOLA DE TOPE
6	181	1	1	1		1	1	1					1	1		1	1	1	1	1	1	1			170 213 720		KLEMM-MUTTER	M8	CLAMP NUT	ECROU DE SERRAGE	TUERCA DE APRIETE
6	182	1	1	1		1	1	1					1	1		1	1	1	1	1	1	1			170 213 730		FEDER FÜR KLEMMUTTER	8	SPRING	RESSORT	MUELLE
6	183	1	1	1		1	1	1					1	1		1	1	1	1	1	1	1			170 213 150		FLÜGELGRIFF KPL.		WING GRIP CPL.	POIGNEE À AILETTE CPL.	MANGO MARIPOSA CPL.
6	184	1	1	1		1	1	1					1	1		1	1	1	1	1	1	1			226 213 340		SPANNRAD	40	TENSIONING WHEEL	ROUE DE SERRAGE	RUEDA TENSORA
6	185	1	1	1		1	1	1					1	1		1	1	1	1	1	1	1			924 204 020		SCHEIBE FÜR SPANNRAD	4X12X0,5	WASHER	DISQUE	ARANDELA
6	186	1	1	1		1	1	1					1	1		1	1	1	1	1	1	1			226 213 380		SCHRAUBE	(P+) M4X8	SCREW	VIS	TORNILLO

DCS3500, DCS3501, DCS4300, DCS4300 (RUS),
 DCS4301, MDE350, MDE354, MDE430, MDE435,
 MEA3500M, MEA3500MR, MEA3500L, MEA3500LR,
 MEA4300L, MEA4300LR, MEA4300G, MEA4300GR,
 EA3500F, EA3501F, EA4300F, EA4301F, CL350, CL430

7

Vergaser
 Carbuřetor
 Carburateur
 Carburador

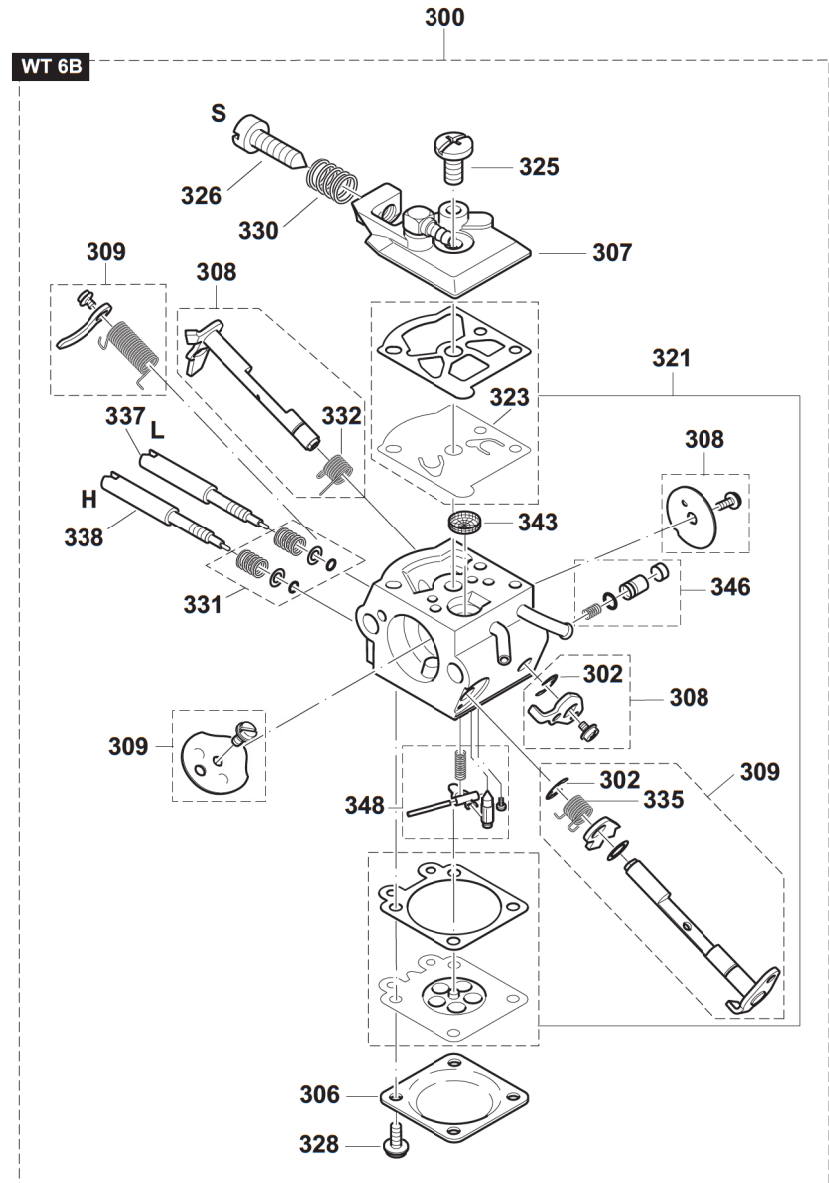
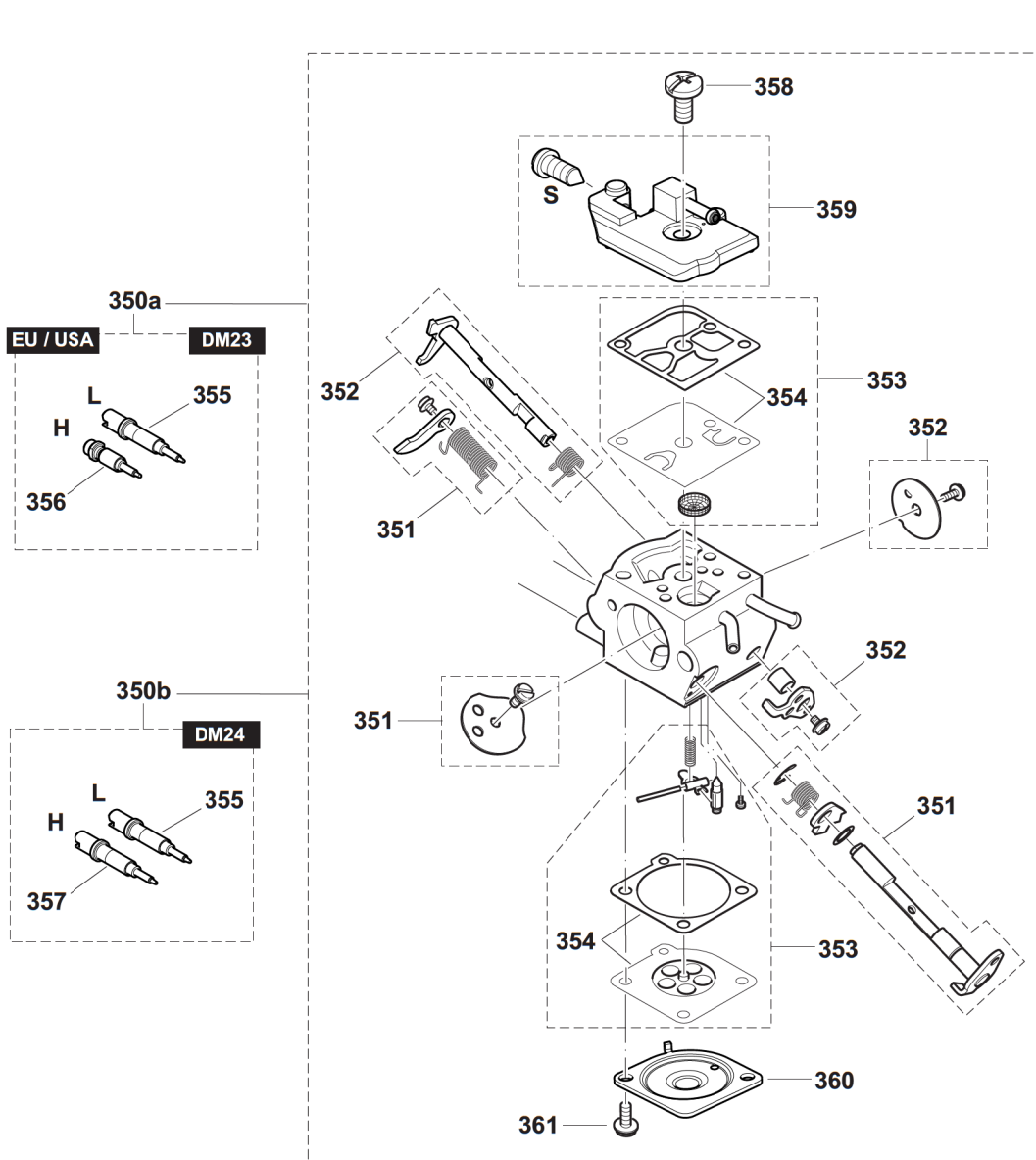

DCS3500, DCS3501, DCS4300, DCS4300 (RUS),
DCS4301, MDE350, MDE354, MDE430, MDE435,
MEA3500M, MEA3500MR, MEA3500L, MEA3500LR,
MEA4300L, MEA4300LR, MEA4300G, MEA4300GR,
EA3500F, EA3501F, EA4300F, EA4301F, CL350, CL430

7

Vergaser
Carburetor
Carburateur
Carburador



Seite / Page	Pos.	DCS3500	DCS3501	DCS4300	DCS4300 (RUS)	DCS4301	MDE350	MDE354	MDE430	MDE435	MEA3500M	MEA3500MR	MEA3500L	MEA3500LR	MEA4300L	MEA4300LR	MEA4300G	MEA4300GR	EA3500F	EA3501F	EA4300F	EA4301F	CL350	CL430	Teil-Nr. Part No. No. de pièce No. de pieza	Hinweise Notes Renseign. Nota	Bezeichnung	Spezifikation Specification	Description	Désignation	Denominación
7	300	1	1	1	1	1	1	1	1	1	1	1	1	1	1	1	1	1	1	1	1	1	1	1	195 151 102		VERGASER	WTE 6B	CARBURETO R CPL.	CARBURATEUR CPL.	CARBURADOR CPL.
7	302	1	1	1	1	1	1	1	1	1	1	1	1	1	1	1	1	1	1	1	1	1	1	1	119 151 350		WELLENSICHERU NG		SHAFT CLIP	TÔLE DE SÉCURITÉ	PIEZA SEGURIDAD ARBÔL
7	306	1	1	1	1	1	1	1	1	1	1	1	1	1	1	1	1	1	1	1	1	1	1	1	021 151 120		MEMBRANDECKE L		DIAPHRAGM COVER	COUVERCLE DE MEMBRANE	TAPA DE MEMBRANA
7	307	1	1	1	1	1	1	1	1	1	1	1	1	1	1	1	1	1	1	1	1	1	1	1	195 151 350		PUMPENDECKEL KPL.		PUMP COVER	COUVERCLE DE POMPE	TAPA DE BOMBA
7	308	1	1	1	1	1	1	1	1	1	1	1	1	1	1	1	1	1	1	1	1	1	1	1	957 151 200		REP.-SATZ DROSSELWELLE		KIT THROTTLE SHAFT	JEU AXE CLAPET D'ÉTRANG.	JUEGO EJE VÁLVULA REG.
7	309	1	1	1	1	1	1	1	1	1	1	1	1	1	1	1	1	1	1	1	1	1	1	1	957 151 210		REP.-SATZ CHOKEWELLE		KIT CHOKE SHAFT	JEU AXE CLAPET D'AIR	JUEGO EJE VÁLVULA AIRE
7	321	1	1	1	1	1	1	1	1	1	1	1	1	1	1	1	1	1	1	1	1	1	1	1	957 151 220		SATZ MEMBRANEN UND DICHTUNGEN		SET DIAPHRAGM / GASKETS	JEU DE MEMBRANES / JOINTS	JUEGO MEMBRANAS / JUNTAS
7	323	1	1	1	1	1	1	1	1	1	1	1	1	1	1	1	1	1	1	1	1	1	1	1	021 151 150		PUMPENMEMBR AN GUMMI		PUMP DIAPHRAGM, RUBBER	MEMBRANE DE POMPE, CAOUTCH.	MEMBRANA DE LA BOMBA, CAUCHO
7	325	1	1	1	1	1	1	1	1	1	1	1	1	1	1	1	1	1	1	1	1	1	1	1	118 151 190		SCHRAUBE		SCREW	VIS	TORNILLO
7	326	1	1	1	1	1	1	1	1	1	1	1	1	1	1	1	1	1	1	1	1	1	1	1	378 151 210		LEERLAUFANSCH LAGSCHRAUBE	S	IDLE SPEED SCREW	VIS DE BUTÉE DE RALENTI	TORNILLO DE TOPE
7	328	4	4	4	4	4	4	4	4	4	4	4	4	4	4	4	4	4	4	4	4	4	4	4	378 151 220		SCHRAUBE		SCREW	VIS	TORNILLO
7	330	1	1	1	1	1	1	1	1	1	1	1	1	1	1	1	1	1	1	1	1	1	1	1	021 151 230		DRUCKFEDER	S	COMPRESSIO N SPRING	RESSORT DE PRESSION	RESORTE DE PRESIÓN
7	331	1	1	1	1	1	1	1	1	1	1	1	1	1	1	1	1	1	1	1	1	1	1	1	957 151 240		SATZ FEDERN UND SCHEIBEN		SET SPRINGS / WASHERS	SET RESSORTS / RONDELLES	JUEGO RESORTES / ARANDELAS
7	332	1	1	1	1	1	1	1	1	1	1	1	1	1	1	1	1	1	1	1	1	1	1	1	001 151 310		DREHFEDER		SPRING	RESSORT	RESORTE
7	335	1	1	1	1	1	1	1	1	1	1	1	1	1	1	1	1	1	1	1	1	1	1	1	195 151 490		DREHFEDER		SPRING	RESSORT	RESORTE
7	337	1	1	1	1	1	1	1	1	1	1	1	1	1	1	1	1	1	1	1	1	1	1	1	195 151 520		LEERLAUF-STELL SCHRAUBE	L	IDLE ADJUSTMENT SCREW	VIS DE RÉGL. DE RALENTI	TORNILLO REGULADOR
7	338	1	1	1	1	1	1	1	1	1	1	1	1	1	1	1	1	1	1	1	1	1	1	1	195 151 530		VOLLGAS-STELL SCHRAUBE	H	MAIN ADJUSTMENT SCREW	VIS DE RÉGL. PLEIN GAZ	TORNILLO REGULADOR
7	343	1	1	1	1	1	1	1	1	1	1	1	1	1	1	1	1	1	1	1	1	1	1	1	021 151 180		SIEB		SCREEN	TAMIS	TAMIZ
7	346	1	1	1	1	1	1	1	1	1	1	1	1	1	1	1	1	1	1	1	1	1	1	1	957 151 070		BESCHLEUNIGUN GSPUMPE KPL.		ACCELERATO R	POMPE DE REPRISE	BOMBA DE ACELERACIÓN

DCS3500, DCS3501, DCS4300, DCS4300 (RUS),
 DCS4301, MDE350, MDE354, MDE430, MDE435,
 MEA3500M, MEA3500MR, MEA3500L, MEA3500LR,
 MEA4300L, MEA4300LR, MEA4300G, MEA4300GR,
 EA3500F, EA3501F, EA4300F, EA4301F, CL350, CL430

7

Vergaser
 Carbuřetor
 Carburateur
 Carburador

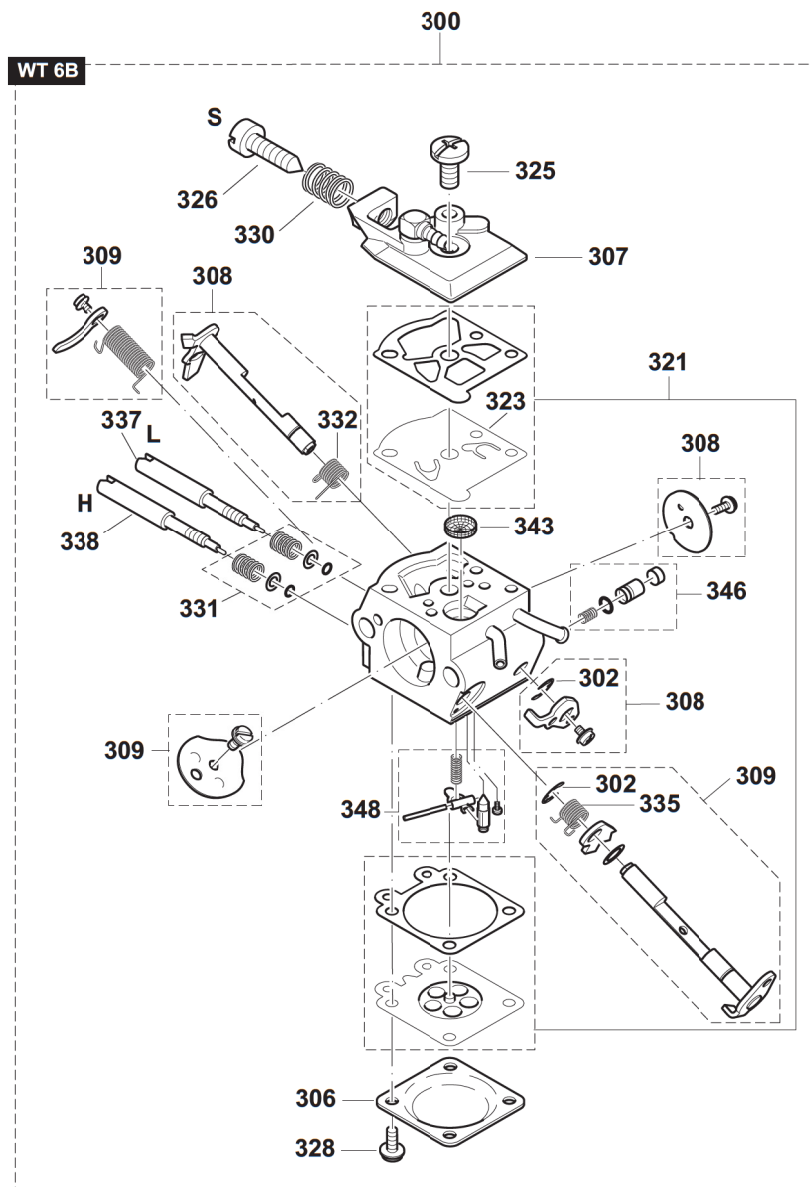
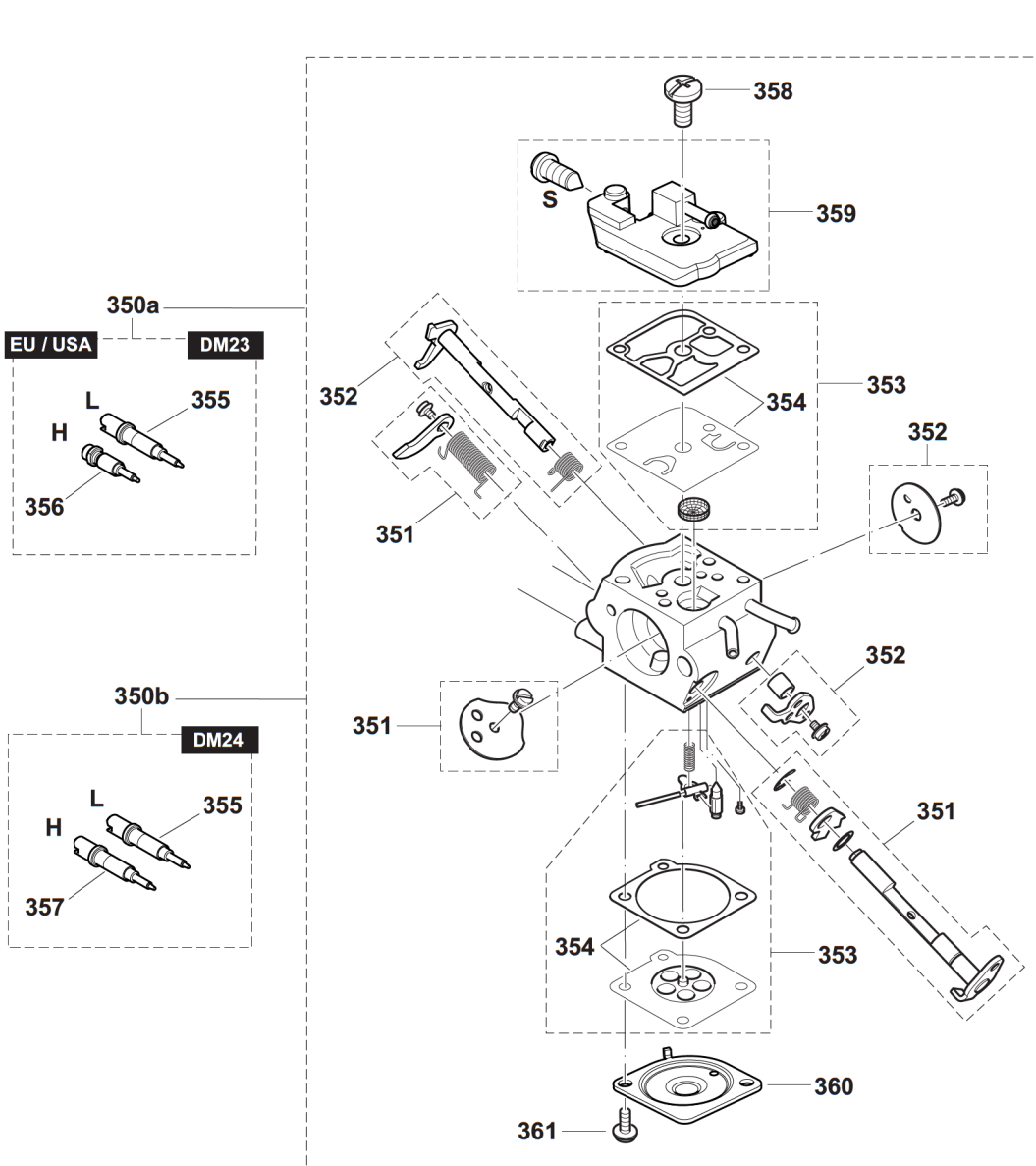

DCS3500, DCS3501, DCS4300, DCS4300 (RUS),
DCS4301, MDE350, MDE354, MDE430, MDE435,
MEA3500M, MEA3500MR, MEA3500L, MEA3500LR,
MEA4300L, MEA4300LR, MEA4300G, MEA4300GR,
EA3500F, EA3501F, EA4300F, EA4301F, CL350, CL430

7

Vergaser
Carburetor
Carburateur
Carburador



Seite / Page	Pos.	DCS3500	DCS3501	DCS4300	DCS4300 (RUS)	DCS4301	MDE350	MDE354	MDE430	MDE435	MEA3500M	MEA3500MR	MEA3500L	MEA3500LR	MEA4300L	MEA4300LR	MEA4300G	MEA4300GR	EA3500F	EA3501F	EA4300F	EA4301F	CL350	CL430	Teil-Nr. Part No. No. de pièce No. de pieza	Hinweise Notes Renseign. Nota	Bezeichnung	Spezifikation Specification	Description	Désignation	Denominación	
7	348	1	1	1	1	1	1	1	1	1	1	1	1	1	1	1	1	1	1	1	1	1	1	1	1	957 151 230		SATZ STEUERTEILE		SET OF CONTROL PARTS	JEU DE PIÈCES DE COMMANDE	JUEGO PIEZAS DE MANDO
7	350a	1	1	1		1													1	1	1	1		1	195 153 200	2012-06 =>	VERGASER	DM23, DD - EU, USA (regulated market)	CARBURETO R	CARBURATEUR	CARBURADOR	
7	350b	1	1	1	1	1	1	1	1	1	1	1	1	1	1	1	1	1	1	1	1	1	1	1	195 153 100	2012-11 =>	VERGASER	DM24 (non regulated market)	CARBURETO R	CARBURATEUR	CARBURADOR	
7	351	1	1	1	1	1	1	1	1	1	1	1	1	1	1	1	1	1	1	1	1	1	1	1	195 153 580		REP.-SATZ CHOKEWELLE		KIT CHOKE SHAFT	JEU AXE CLAPET D'AIR	JUEGO EJE VÁLVULA AIRE	
7	352	1	1	1	1	1	1	1	1	1	1	1	1	1	1	1	1	1	1	1	1	1	1	1	195 153 570		REP.-SATZ DROSSELWELLE		KIT THROTTLE SHAFT	JEU AXE CLAPET D'ÉTRANG.	JUEGO EJE VÁLVULA REG.	
7	353	1	1	1	1	1	1	1	1	1	1	1	1	1	1	1	1	1	1	1	1	1	1	1	195 153 510		REPARATURSAT Z VERGASER		REPAIR KIT	JEU DE RÉPARATION	JUEGO DE REPARAR	
7	354	1	1	1	1	1	1	1	1	1	1	1	1	1	1	1	1	1	1	1	1	1	1	1	195 153 500		SATZ DICHTUNGEN / MEMBRANEN		SET GASKETS / DIAPHRAGM	JEU DE JOINT / MEMBRANE	JUEGO JUNTA / MEMBRANA	
7	355	1	1	1	1	1	1	1	1	1	1	1	1	1	1	1	1	1	1	1	1	1	1	1	195 153 340		STELLSCHRAUBE L		ADJUST SCREW	VIS DE REGLAGE	TORNILLO DE AJUSTE	
7	356	1	1	1		1													1	1	1	1		1	195 153 350		STELLSCHRAUBE	H, DD - EU, USA (regulated market)	ADJUST SCREW	VIS DE REGLAGE	TORNILLO DE AJUSTE	
7	357	1	1	1	1	1	1	1	1	1	1	1	1	1	1	1	1	1	1	1	1	1	1	1	195 153 470		STELLSCHRAUBE	H (non regulated market)	ADJUST SCREW	VIS DE REGLAGE	TORNILLO DE AJUSTE	
7	358	1	1	1	1	1	1	1	1	1	1	1	1	1	1	1	1	1	1	1	1	1	1	1	038 153 360		SCHRAUBE FÜR PUMPENDECKEL		SCREW	VIS	TORNILLO	
7	359	1	1	1	1	1	1	1	1	1	1	1	1	1	1	1	1	1	1	1	1	1	1	1	195 153 230		PUMPENDECKEL KPL.		PUMP COVER CPL.	COUVERCLE DE POMPE CPL.	TAPA DE BOMBA CPL.	
7	360	1	1	1	1	1	1	1	1	1	1	1	1	1	1	1	1	1	1	1	1	1	1	1	195 153 360		MEMBRANDECKE L		DIAPHRAGM COVER	COUVERCLE DE MEMBRANE	TAPA DE MEMBRANA	
7	361	2	2	2	2	2	2	2	2	2	2	2	2	2	2	2	2	2	2	2	2	2	2	2	001 153 020		SCHRAUBE FÜR REGELDECKEL		SCREW	VIS	TORNILLO	

DCS3500, DCS3501, DCS4300, DCS4300 (RUS),
DCS4301, MDE350, MDE354, MDE430, MDE435,
MEA3500M, MEA3500MR, MEA3500L, MEA3500LR,
MEA4300L, MEA4300LR, MEA4300G, MEA4300GR,
EA3500F, EA3501F, EA4300F, EA4301F, CL350, CL430

8

Sägeschienen, Sägeketten, Werkzeug
Guide bars, saw chains, tools
Guide-chaîne, chaînes, outils
Rieles guía, cadenas sierra, herramientas

Makita[®]

3/8"

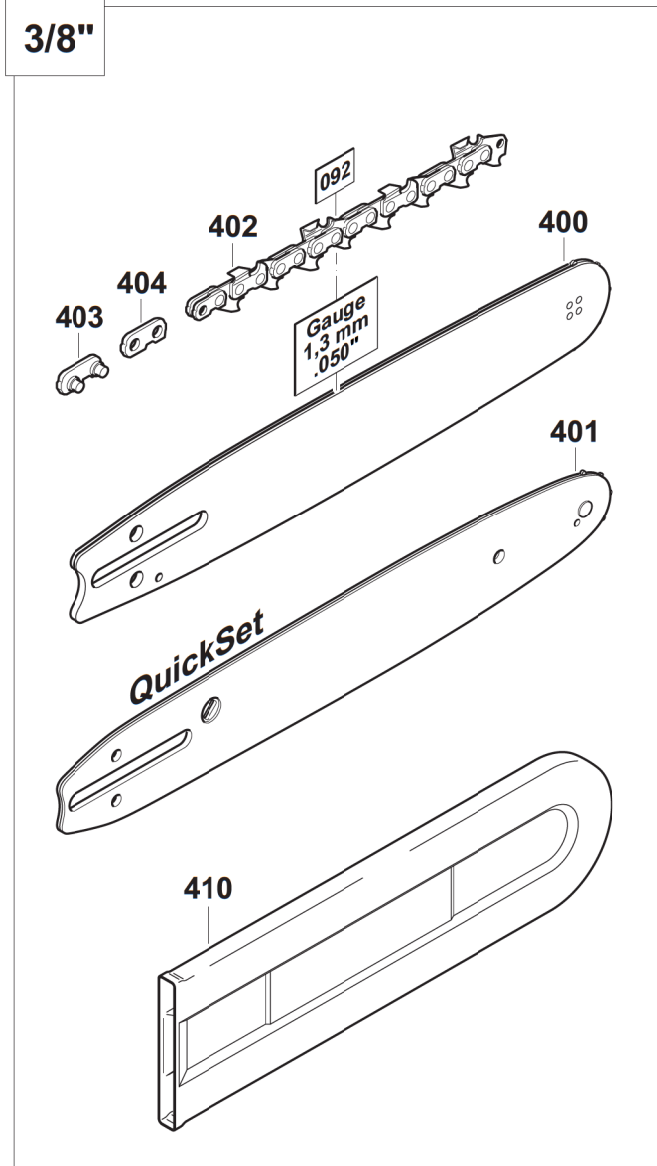

.325"

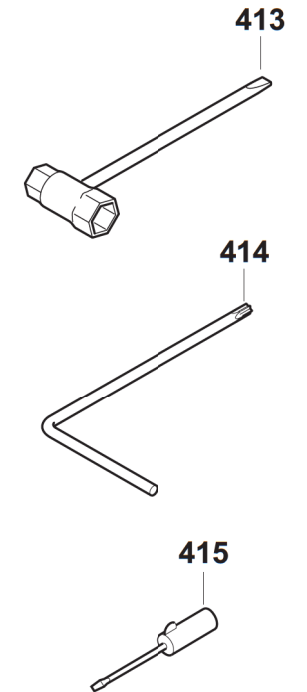
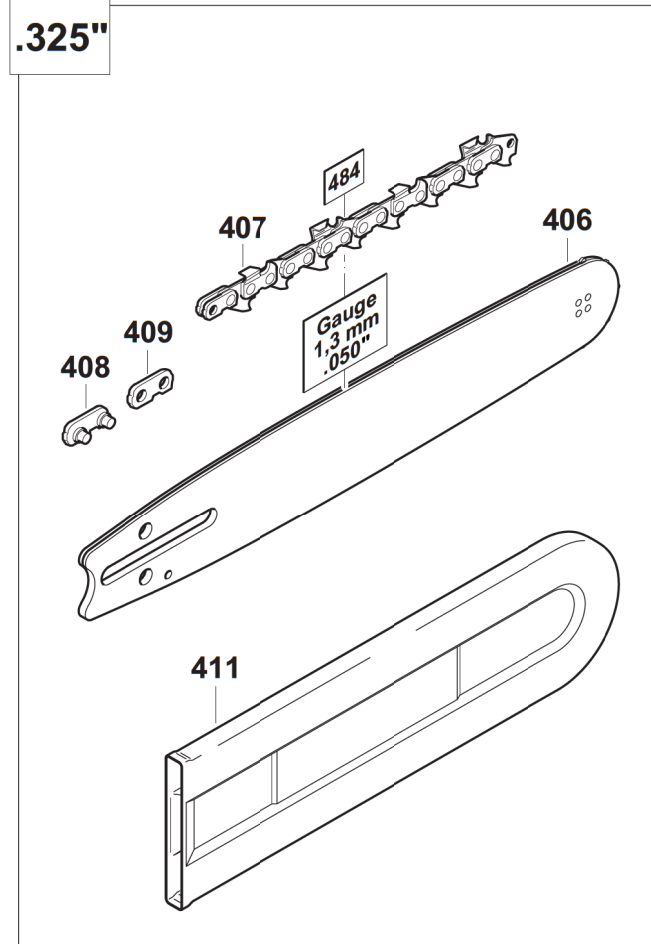

DCS3500, DCS3501, DCS4300, DCS4300 (RUS),
DCS4301, MDE350, MDE354, MDE430, MDE435,
MEA3500M, MEA3500MR, MEA3500L, MEA3500LR,
MEA4300L, MEA4300LR, MEA4300G, MEA4300GR,
EA3500F, EA3501F, EA4300F, EA4301F, CL350, CL430

8

Sägeschienen, Sägeketten, Werkzeug
Guide bars, saw chains, tools
Guide-chaîne, chaînes, outils
Rieles guía, cadenas sierra, herramientas



Seite / Page	Pos.	DCS3500	DCS3501	DCS4300	DCS4300 (RUS)	DCS4301	MDE350	MDE354	MDE430	MDE435	MEA3500M	MEA3500MR	MEA3500L	MEA3500LR	MEA4300L	MEA4300LR	MEA4300G	MEA4300GR	EA3500F	EA3501F	EA4300F	EA4301F	CL350	CL430	Teil-Nr. Part No. No. de pièce No. de pieza	Hinweise Notes Renseign. Nota	Bezeichnung	Spezifikation Specification	Description	Désignation	Denominación
8	400	1	1	1	1	1		1	1				1	1	1	1			1	1	1	1			442 040 661		STERNSCHIENE	3/8" .050" 40cm-16"	SPROCKET NOSE BAR	GUIDE À ÉTOILE	GUÍA CON ESTRELLA
8	400	1	1				1				1	1							1	1					442 035 661		STERNSCHIENE	3/8" .050" 35cm-14"	SPROCKET NOSE BAR	GUIDE À ÉTOILE	GUÍA CON ESTRELLA
8	400	1	1																1	1					442 030 661		STERNSCHIENE	3/8" .050" 30cm-12"	SPROCKET NOSE BAR	GUIDE À ÉTOILE	GUÍA CON ESTRELLA
8	400																						1		422 035 661		STERNSCHIENE	3/8" .050" 35cm-14" RABBIT	SPROCKET NOSE BAR	GUIDE À ÉTOILE	GUÍA CON ESTRELLA
8	400																						1		422 040 661		STERNSCHIENE	3/8" .050" 40cm-16" RABBIT	SPROCKET NOSE BAR	GUIDE À ÉTOILE	GUÍA CON ESTRELLA
8	401	1	1																1	1					442 040 061	ACC.	STERNSCHIENE QUICKSET	3/8" .050" 40cm-16"	SPROCKET NOSE BAR	GUIDE À ÉTOILE	GUÍA CON ESTRELLA
8	401	1	1																1	1					442 035 061	ACC.	STERNSCHIENE QUICKSET	3/8" .050" 35cm-14"	SPROCKET NOSE BAR	GUIDE À ÉTOILE	GUÍA CON ESTRELLA
8	401	1	1																1	1					442 030 061	ACC.	STERNSCHIENE QUICKSET	3/8" .050" 30cm-12"	SPROCKET NOSE BAR	GUIDE À ÉTOILE	GUÍA CON ESTRELLA
8	402	1	1	1	1	1		1	1			1	1	1	1	1			1	1	1	1			531 492 656		SÄGEKETTE	3/8" .050" 40cm-16"	SAW CHAIN	CHAÎNE	CADENA
8	402	1	1				1				1	1							1	1					528 092 652		SÄGEKETTE	3/8" .050" 35cm-14"	SAW CHAIN	CHAÎNE	CADENA
8	402	1	1																1	1					528 092 646		SÄGEKETTE	3/8" .050" 30cm-12"	SAW CHAIN	CHAÎNE	CADENA
8	402																						1		528 091 052		SÄGEKETTE	3/8" .050" 35cm-14"	SAW CHAIN	CHAÎNE	CADENA
8	402																						1		528 091 056		SÄGEKETTE	3/8" .050" 40cm-16"	SAW CHAIN	CHAÎNE	CADENA
8	403	1	1	1	1	1	1	1	1		1	1	1	1	1	1			1	1	1	1	1	1	558 092 010		AUSSENLASCHE MIT NIET	3/8" .050"	TIE STRAP WITH RIVETS	ECLISSE EXTER. A. RIVETS	TIRA EXTER. CON REMACHE
8	404	1	1	1	1	1	1	1	1		1	1	1	1	1	1			1	1	1	1	1	1	558 092 000		SICHERHEITSLAS CHE	3/8" .050"	SAFETY TIE STRAP	ECLISSE DE SÉCURITÉ	TIRA SEGURIDAD
8	406			1	1	1				1							1	1							444 045 141		STERNSCHIENE	.325" .050" 45cm-18"	SPROCKET NOSE BAR	GUIDE À ÉTOILE	GUÍA CON ESTRELLA
8	406			1	1	1																			444 038 141		STERNSCHIENE	.325" .050" 38cm-15"	SPROCKET NOSE BAR	GUIDE À ÉTOILE	BARRA GUÍA
8	406			1	1	1																			444 033 141		STERNSCHIENE	.325" .050" 33cm-13"	SPROCKET NOSE BAR	GUIDE À ÉTOILE	BARRA GUÍA
8	407			1	1	1				1							1	1							532 484 072		SÄGEKETTE	.325" .050" 45cm-18"	SAW CHAIN	CHAÎNE	CADENA
8	407			1	1	1																			532 484 056		SÄGEKETTE	.325" .050" 33cm-13"	SAW CHAIN	CHAÎNE	CADENA
8	407			1	1	1																			532 484 064		SÄGEKETTE	.325" .050" 38cm-15"	SAW CHAIN	CHAÎNE	CADENA
8	408			1	1	1				1							1	1							510 084 020		AUßENLASCHE MIT NIET	.325" .050"	TIE STRAP WITH RIVETS	ECLISSE AVEC RIVETS	TIRA EXT. CON REMACHES
8	409			1	1	1				1							1	1							510 084 040		AUßENLASCHE	.325" .050"	TIE STRAP	ECLISSE EXTERIEURE	TIRA EXT.
8	410	1	1				1				1	1							1	1					952 010 630		KETTENSCHUTZ	30 cm (3/8")	CHAIN PROTECTION	PROTECTION CHAÎNE	PROTECTOR DE CADENA
8	410	1	1	1	1	1		1	1			1	1	1	1				1	1	1	1			952 010 640		KETTENSCHUTZ	43 cm (3/8")	CHAIN PROTECTION	PROTECTION CHAÎNE	PROTECTOR DE CADENA

DCS3500, DCS3501, DCS4300, DCS4300 (RUS),
DCS4301, MDE350, MDE354, MDE430, MDE435,
MEA3500M, MEA3500MR, MEA3500L, MEA3500LR,
MEA4300L, MEA4300LR, MEA4300G, MEA4300GR,
EA3500F, EA3501F, EA4300F, EA4301F, CL350, CL430

8

Sägeschienen, Sägeketten, Werkzeug
Guide bars, saw chains, tools
Guide-chaîne, chaînes, outils
Rieles guía, cadenas sierra, herramientas

Makita[®]

3/8"

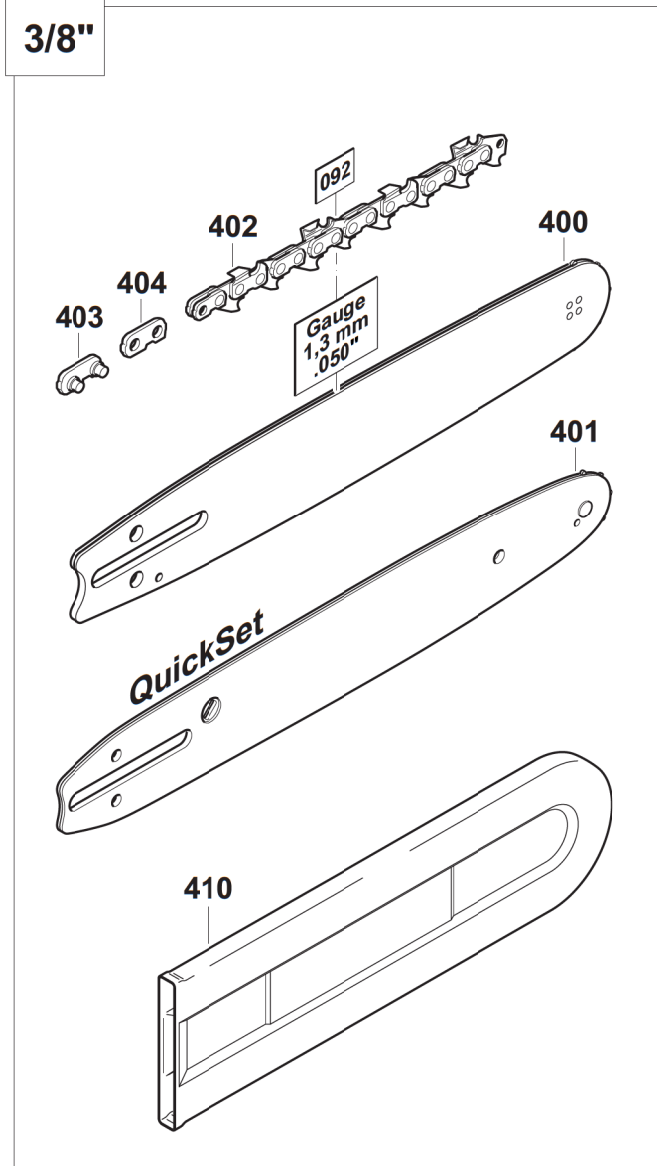

.325"

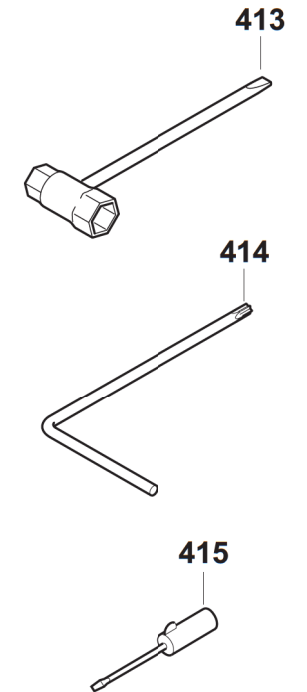
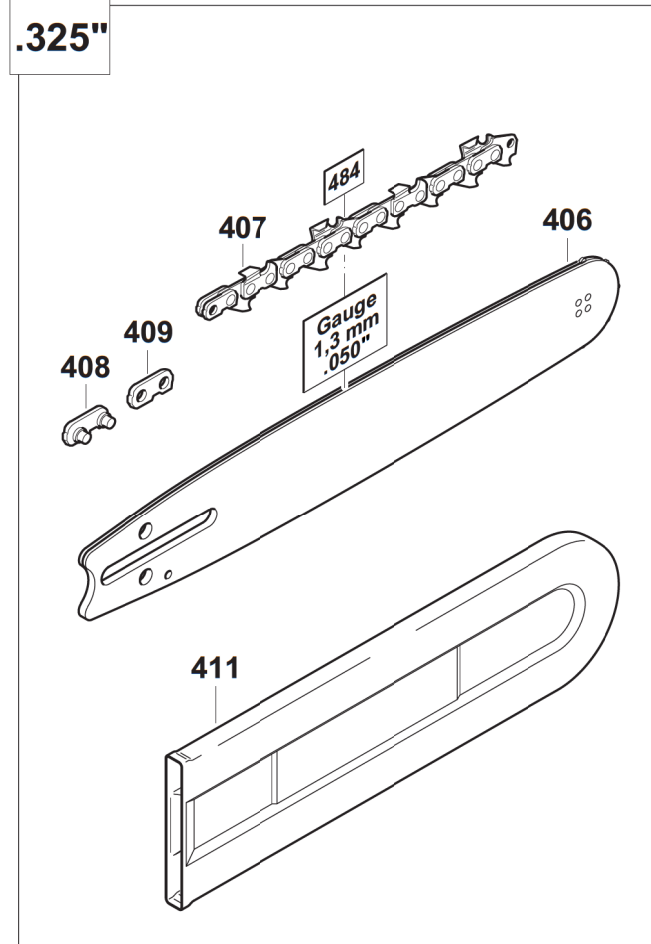

DCS3500, DCS3501, DCS4300, DCS4300 (RUS),
DCS4301, MDE350, MDE354, MDE430, MDE435,
MEA3500M, MEA3500MR, MEA3500L, MEA3500LR,
MEA4300L, MEA4300LR, MEA4300G, MEA4300GR,
EA3500F, EA3501F, EA4300F, EA4301F, CL350, CL430

8

Sägeschienen, Sägeketten, Werkzeug
Guide bars, saw chains, tools
Guide-chaîne, chaînes, outils
Rieles guía, cadenas sierra, herramientas



Seite / Page	Pos.	DCS3500	DCS3501	DCS4300	DCS4300 (RUS)	DCS4301	MDE350	MDE354	MDE430	MDE435	MEA3500M	MEA3500MR	MEA3500L	MEA3500LR	MEA4300L	MEA4300LR	MEA4300G	MEA4300GR	EA3500F	EA3501F	EA4300F	EA4301F	CL350	CL430	Teil-Nr. Part No. No. de pièce No. de pieza	Hinweise Notes Renseign. Nota	Bezeichnung	Spezifikation Specification	Description	Désignation	Denominación	
8	410																							1	1	952 010 740		KETTENSCHUTZ	35/40 cm RABBIT (3/8")	CHAIN PROTECTION	PROTECTION CHAÎNE	PROTECTOR DE CADENA
8	411			1	1	1															1	1				952 010 630		KETTENSCHUTZ	30 cm (.325")	CHAIN PROTECTION	PROTECTION CHAÎNE	PROTECTOR DE CADENA
8	411			1	1	1				1							1	1			1	1				952 020 640		KETTENSCHUTZ	40 cm (.325")	CHAIN PROTECTION	PROTECTION CHAÎNE	PROTECTOR DE CADENA
8	413	1	1	1		1	1	1	1	1																941 719 131		KOMBISCHLÜSSEL	SW 13/19 mm	UNIVERSAL WRENCH	CLÉ COMBINÉE	LLAVE DE BUJIA
8	413				1						1	1	1	1	1	1	1	1	1	1	1	1	1	1	1	941 713 160		KOMBISCHLÜSSEL	SW 13/16	UNIVERSAL WRENCH	CLÉ COMBINÉE	LLAVE DE BUJIA
8	414	1	1	1	1	1	1	1	1	1	1	1	1	1	1	1	1	1	1	1	1	1	1	1	1	940 827 000		WINKELSCHRAUBENDREHER	T27	ANGLED SCREW DRIVER	CLÉ ANGLE	LLAVE ANGULAR
8	415	1	1	1	1	1	1	1	1	1	1	1	1	1	1	1	1	1	1	1	1	1	1	1	1	944 340 001		SCHRAUBENDREHER		SCREWDRIVER	TOURNEVIS	DESTORNILLADOR

DCS3500, DCS3501, DCS4300, DCS4300 (RUS),
 DCS4301, MDE350, MDE354, MDE430, MDE435,
 MEA3500M, MEA3500MR, MEA3500L, MEA3500LR,
 MEA4300L, MEA4300LR, MEA4300G, MEA4300GR,
 EA3500F, EA3501F, EA4300F, EA4301F, CL350, CL430



	Zeichenerklärung	Key to symbols	Légende	Explicación de símbolos
=> 1999999 2000000 => 2003.04 => TI 2003/07 Acc. = { m Corr.	Produktion bis Serien-Nr. Neues Teil ab Serien-Nr. Neues Teil ab Jahr / Monat Siehe Technische Information Jahr / Nr. Zubehör (nicht im Lieferumfang) Keine Serienausführung, jedoch verwendbar Beinhaltet Positions-Nr. Meterware Druckfehlerberichtigung	Production to serial number New part from serial number New part from Year / Month See Technical Information Year / No. Accessories (not included in the delivery inventory) No standard execution, may be used Contains item number Sold by the meter Error correction	Production jusqu'à n° de série Nouveau pièce à partir du n° de série Nouveau pièce à partir de année / mois Voir information technique année / n° Accessoires (non compris dans la livraison) Aucune exécut. en série, cependant utilisable contient n° de numéro Au mètre Rectification d'erreurs	Producción hasta N° de serie Pieza nueva a partir de N° de serie Pieza nueva a partir de año / mes Véase inform. técnico año / N° Accesorios (no incluido en la extensión del suministro) No es de serie, pero sirve Contiene pos N° Por metro Fe de erratas
	Änderungen vorbehalten	Specifications subject to change without notice	Changements sans préavis	Mejoras constructivas sin previo aviso